

One Stop Solution Of Quality Valves

PLUG VALVE



PLUG VALVE



New Plug Valves



Non-Lubricated

Extended Packing Plug Valves

Sleeved Plug Valves

Lined Plug Valves

Double Block & Bleed Plug Valves

Lubricated Plug Valves



PLUG VALVES HOW TO ORDER

■ **EXAMPLE** : PLUG VALVE, FIG P250J, PJ 316 / 316 /304-12"G

P	VALVE TYPE	2	PORT TYPE	5	CLASS	0	END TYPE	J	OPTION(I)	PJ	OPTION(II)
P	PLUG VALVE	2	2-WAY	5	ANSI 150	0	FLANGED END	N/A	ANSI	PJ	PARTIAL JACKET
B	BALL CHECK VALVE	3	3-WAY	3	ANSI 300	L	LINED TYPE	J	JIS	FJ	FULL JACKET
S	SWING CHECK VALVE	4	4-WAY	6	ANSI 600	OF	FULL BORE	DIN	DIN	CV	CONTROL VALVES
		5	5-WAY	9	ANSI 900	OM	METAL SEATED				
				15	ANSI 1500	OL	LUBRICATED				
				5	JIS10K	OBW	BUTT WELD				
				3	JIS20K	OSC	SCREW TYPE				
				6	JIS40K	OSW	SOCKET TYPE				
				9	JIS63K	DBB	DOUBLE BLOCK & BLEED TYPE				

316	BODY MATERIAL	316	PLUG MATERIAL	304	OPTION MATERIAL	12" SIZE	G	OPERATOR
WCB	WCB	WCB	WCB	304	SUS304	1/2"	N/A	WRENCH TYPE
304	CF8	304	CF8	316	SUS 316	3/4"	G	WORM GEAR TYPE
316	CF8M	316	CF8M	A283	A283 Gr.C	1"		
A20	CN7M	A20	CN7M			1.1/2"		
CD4M	CD4MCU	CD4M	CD4MCU			2"		
304L	CF3	304L	CF3			2.1/2"		
316L	CF3M	316L	CF3M			3"		
MO	MONEL	MO	MONEL			4"		
						5"		
HC	HASTELLOY C	HC	HASTELLOY C			6"		
TI	TITANIUM	TI	TITANIUM			8"		
PFA	PFA LINED	PFA	PFA LINED			10"		
						12"		
						14"		
						18"		
						20"		
						24"		



TEFLON SLEEVED PLUG VALVES

TEFLON SLEEVED PLUG VALVES

Non-Lubricated

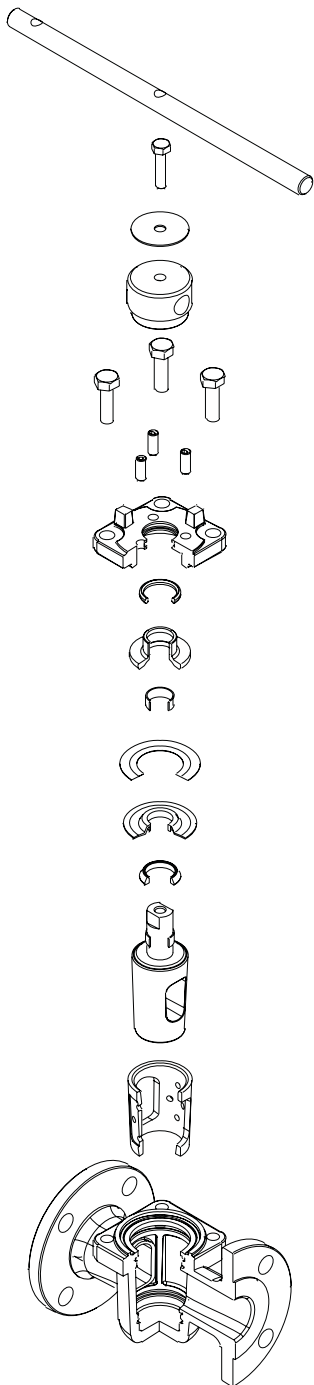

■ PART OF STANDARD MATERIAL

NO	DESCRIPTION	MATERIAL	SPECIFICATION
1	WRENCH	CARBON STEEL	1045. PAINTED
2	HUB BOLT	CARBON STEEL	SUS304
3	NAME PLATE	STAINLESS STEEL	SUS304
4	HUB	CARBON STEEL	ASTM A216 WCB
5	COVER BOLT	STAINLESS STEEL	SUS304
6	ADJUSTING BOLT	STAINLESS STEEL	SUS304
7	COVER	STAINLESS STEEL	
8	O-RING	VITON	
9	THRUST COLLAR	STAINLESS STEEL	SUS304
10	ANSTATIC BEARING	RTFE	
11	METAL DIAPHRAGM	STAINLESS STEEL	SUS304
12	PTFE DIAPHRAGM	RTFE	
13	WEDGE RING	RTFE	
14	PLUG	STAINLESS STEEL	ASTM A351 CF8M
15	SLEEVE	RTFE	
16	BODY	STAINLESS STEEL	ASTM A351 CF8M

TEFLON SLEEVED PLUG VALVES

Non-Lubricated

- ▶ Design more economical, flexible, and compact fluid handling systems.

Bi-directional flow, simple actuation, light weight, compact design, and multi-port configurations all facilitated by an improved system design.

- ▶ Superior, Longer-lasting in-Line Sealing

The PTFE sleeve completely surrounds the plug. The sleeve provides a large, circumferential sealing surface from port to port. Open, closed, or rotating, the seal is assured. No ball or gate valve can match this sealing power.

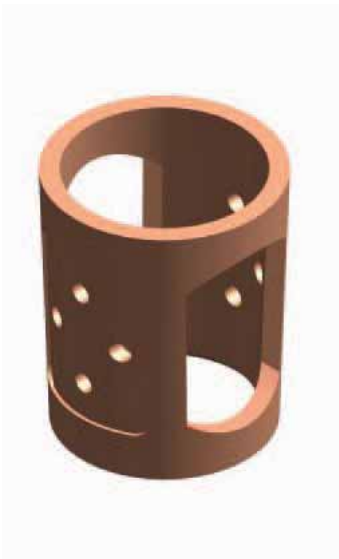

- ▶ Secure sealing with no cold-flow, deformation blow-out, or rotating of the sleeve

The sleeve is securely/safely nestled in the valve body. High-pressure ribs, top and bottom retention, and 360 degree port lips all assure sleeve containment.

- ▶ No seizing. No sticking

As the plug rotates, the 360 degree lips provide a self cleaning action to remove scaling and adhering media.

- ▶ No cavities. No contamination.

There are no body cavities where flow media can accumulate and contaminate future processing. The cavity-free design also prevents sticking.

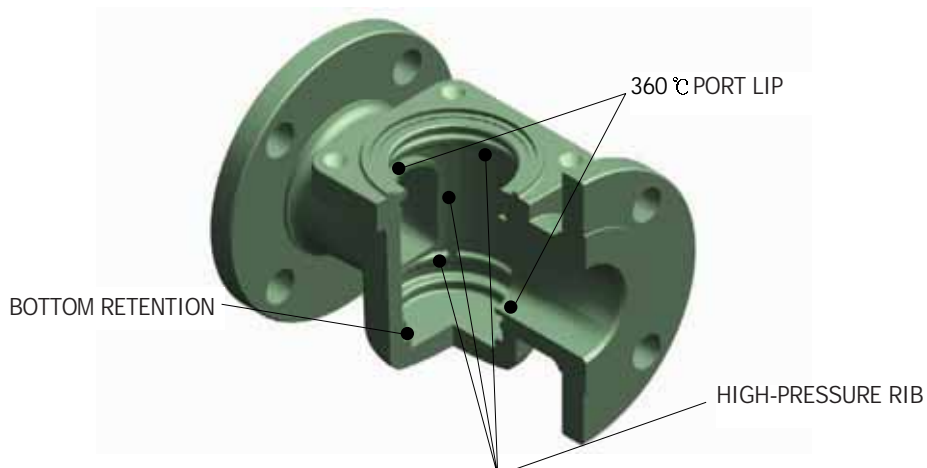

TOP SEAL STRUCTURE OF TEFLON SLEEVED PLUG VALVES

Non-Lubricated

THE ANTISTATIC THRUST COLLAR

3-POINT STANDED THRUST COLLAR HOLDS THE STEM TIGHTLY AND PUSHES THE DIAPHRAM WITH DEFINED PRESSURE.

HOLD THE STEM TIGHTLY AND REMOVES ANY STATIC ELECTRICITY BUILT UP INSIDE THE VALVE.

WEATHER PROOF TYPE

WEATHER PROOF O-RING WILL PREVENT ANY PENETRATION OF RAIN OR FLUID FROM THE OUTSIDE OF THE VALVE AND THEREFORE NO OXIDATION OCCURS AT THE INSIDE OF THE VALVE.

THE FOURTHLY SEAL

THE SPECIALLY DESIGNED LIP STRUCTURE OF THE TEFLON DIAPHRAGM WILL PREVENT ANY LEAKAGE FROM THE TOP OF THE PLUG.

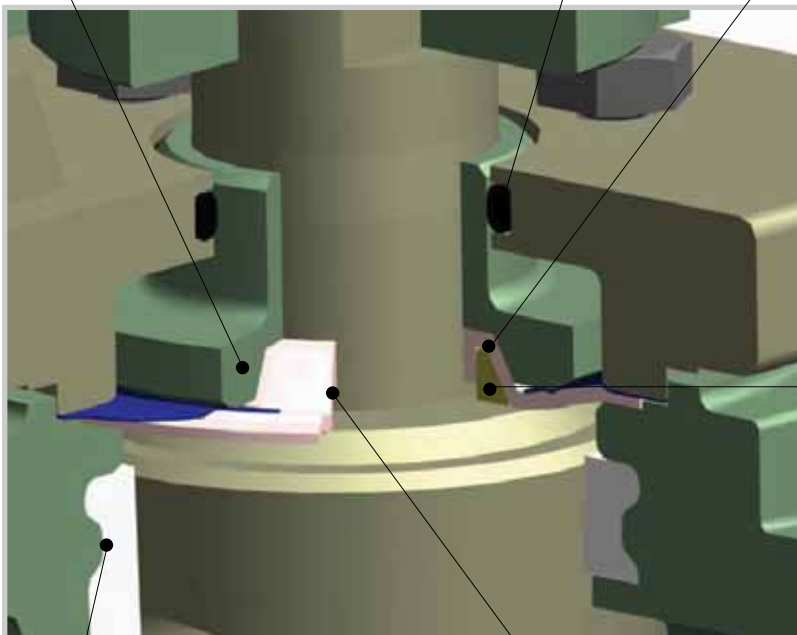

THE TERTIARY SEAL

RTFE TEFLON WEDGE RING AND PLUG FIT TIGHTLY

THE PRIMARY SEAL

THE TOUCHED FACE BETWEEN THE TEFLON SLEEVE AND THE PLUG WILL NOT ALLOW ANY LEAKAGE OF FLOW MEDIA

THE SECONDARY SEAL

THE SPECIALLY DESIGNED LIP STRUCTURE OF THE TEFLON DIAPHRAGM WILL HOLD THE STEM MORE TIGHTLY WITH ANY LEAKED GAS OR FLUID FROM THE TOP OF PLUG.

SLEEVED PLUG VALVES

Non-Lubricated



FIG P250 316/316
SLEEVED PLUG VALVES

SLEEVED PLUG VALVE's Characteristic and Merits

1. Completely no leakage.

- ① PLUG & tapered pipe of the Teflon Sleeve use the contact method, giving absolutely no leakage problems compared to other Process Valves.
- ② Stem seal structure has secured the security design and gives absolutely no leakage characteristic of magnet powered type.
- ③ Water proof type characteristic has been added. The stem seal parts of the products of other enterprises leak and after long usage, corrosion takes place in the sealing but our product has used the sealing structure in the stem part and the covering part which gives absolutely no leakages for longtime use eventually increasing the life span of the product. (Top seal structure)

2. No extra space in the valve.

The passage way of the valve has no extra space like other process valves allowing full control and open/close function, semi-permanent life span.

3. No need of maintenance and repair

Having no extra space, there is no worry that moving materials might clog up inside the pipe.

- ① The seal pressure made by the abrasion of the Teflon sleeve is recontrolled by the cover of ADJ. Bolt for semipermanent sealing.
- ② Inside the body of the port is a Metal lib with Self-cleaning function which can control all sticky and solid materials.
- ③ Top entry type allowing maintenance in on-line status possible. Valve which doesn't need much maintenance.

Non-Lubricated Type

Material - Body, Plug

WCB, LCB, 304, 304L, 316, 316L, A20, CD4M, HB, HC, MO, INCONEL, TI, ZR

Sleeve Material - PTFE, RTFE(GLASS, BRASS, GRAPHITE), TFM

SIZE 1/2" ~ 24"

Use Temperature - 50℃ ~ 230℃

Main Fluid : Toxic, Flammable, Explosive Fluid Line and No-leakage required Line

TEFLON SLEEVED PLUG VALVES

P250 Flanged ANSI class 150

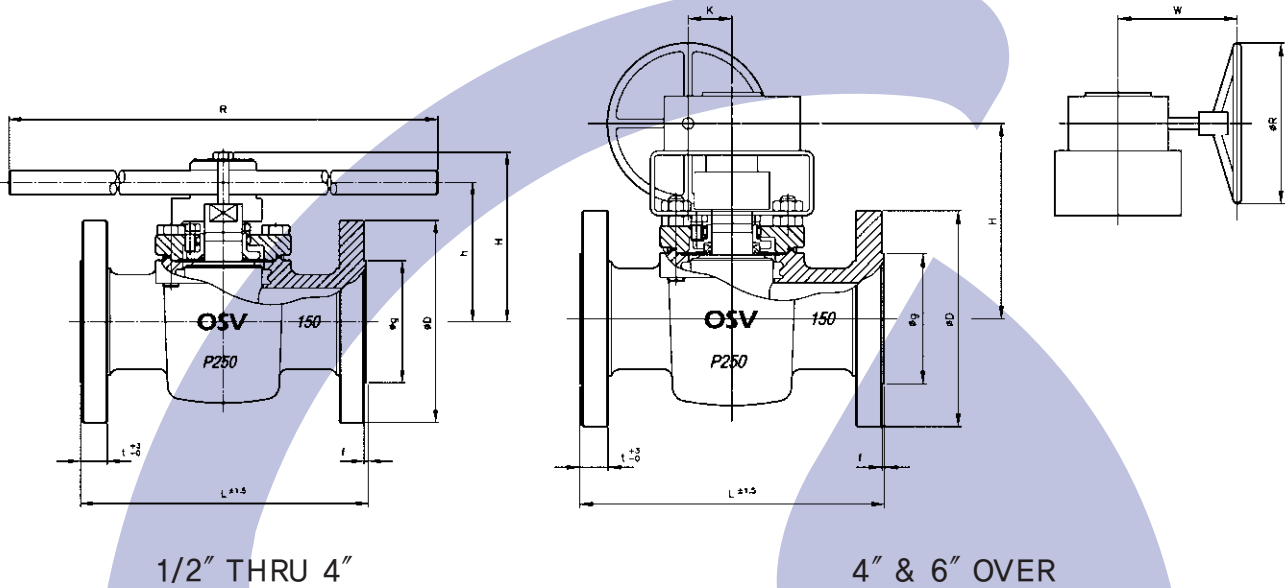

DIMENSIONS

UNIT : MM

IN	MM	L	END FLANGES				BOLT HOLE			h	H	R	K	W	OPERATOR	REMARK
			D	g	t	f	PCD	N	d							
1/2	15	108	89	35	9.7	1.6	60.5	4	16	80	-	180	-	-	WITH	
3/4	20	117	98	43	10.4	1.6	70.0	4	16	80	-	180	-	-	WRENCH	
1	25	127	108	51	11.2	1.6	79.5	4	16	75	96	222	-	-		
1.1/2	40	165	127	73	14.2	1.6	98.5	4	16	91	116	320	-	-		
2	50	178	152	92	15.8	1.6	120.5	4	19	106	130	460	-	-		
2.1/2	65	190	178	105	17.5	1.6	139.5	4	19	121	145	600	-	-		
3	80	203	190	127	19.1	1.6	152.5	4	19	121	145	600	-	-		
4	100	229	229	157	23.9	1.6	190.5	8	19	150	178	750	-	-		
4	100	229	229	157	23.9	1.6	190.5	8	19	-	233	250	53	177	WITH	
6	150	267	279	216	25.4	1.6	241.5	8	22	-	260	300	62.5	228	WORM	
8	200	292	343	270	28.6	1.6	298.5	8	22	-	343	300	62.5	228	GEAR	
10	250	330	406	324	30.2	1.6	362.0	12	25	-	374	500	91.5	297		
12	300	356	483	381	31.8	1.6	432.0	12	25	-	464	560	113	330		
14	350	381	533	413	35.1	1.6	476.0	12	29	-	575	630	153	370		
16	400	762	597	470	36.6	1.6	539.5	16	29	-	615	560	113	360		
18	450	864	635	533	39.7	1.6	578.0	16	32	-	725	630	153	420		
20	500	914	698	584	42.9	1.6	635.0	20	32	-	829	800	235	552		
24	600	1067	813	692	52.4	1.6	749.5	20	35	-	885	900	281	602		

TEFLON SLEEVED PLUG VALVES

P230 Flanged ANSI class 300

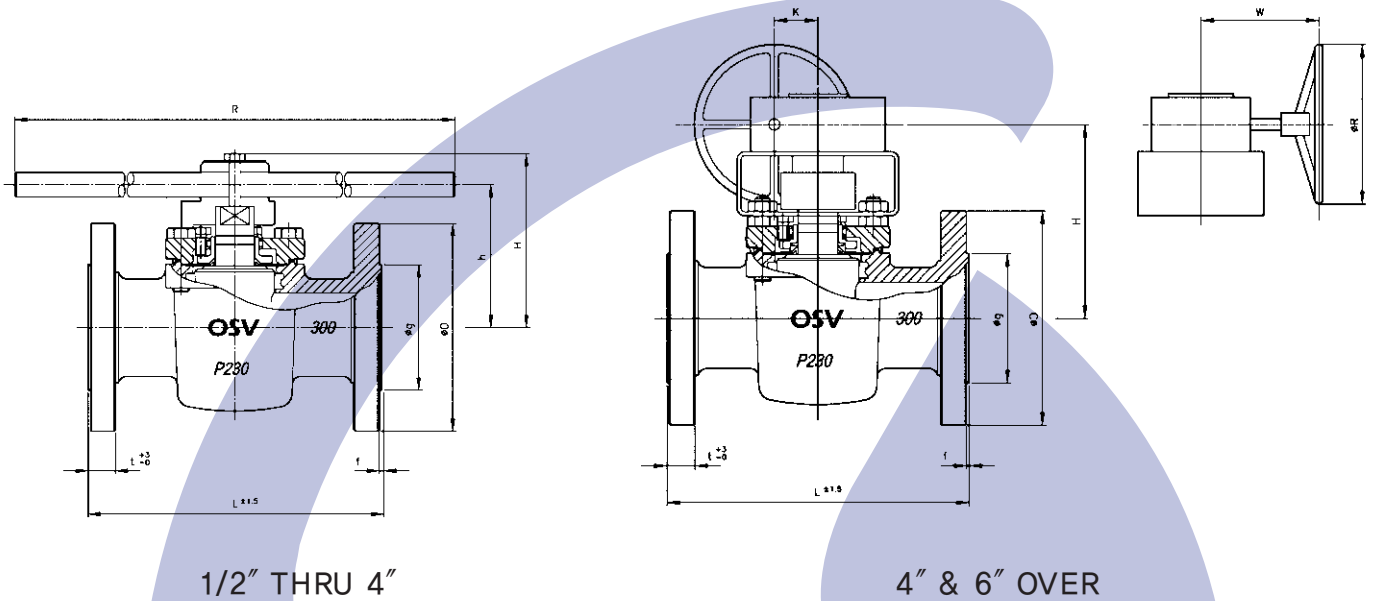

1/2" THRU 4"

4" & 6" OVER

DIMENSIONS

UNIT : MM

IN	MM	END FLANGES									h	H	R	K	W	OPERATOR	REMARK
		L	D	g	t	f	BOLT HOLE										
							PCD	N	d								
1/2	15	140	95	35	14.3	1.6	66.5	4	16	80	-	180	-	-	WITH WRENCH		
3/4	20	152	117	43	15.9	1.6	82.5	4	19	80	-	180	-	-			
1	25	165	124	51	17.5	1.6	89.0	4	19	75	96	222	-	-			
1.1/2	40	190	156	73	20.7	1.6	114.5	4	22	91	116	320	-	-			
2	50	216	165	92	22.3	1.6	127.0	8	19	106	130	460	-	-			
2.1/2	65	241	190	105	25.4	1.6	149.0	8	22	121	145	600	-	-			
3	80	283	210	127	28.6	1.6	168.0	8	22	121	145	600	-	-			
4	100	305	254	157	31.8	1.6	200.0	8	22	150	178	750	-	-			
4	100	305	254	157	31.8	1.6	200.0	8	22	-	233	250	53	177	WITH WORM GEAR		
6	150	403	318	216	36.6	1.6	270.0	12	22	-	260	300	62.5	228			
8	200	419	381	270	41.3	1.6	330.0	12	22	-	343	300	62.5	228			
10	250	457	444	324	47.7	1.6	387.5	16	29	-	374	500	91.5	297			
12	300	502	521	381	50.8	1.6	451.0	16	32	-	464	560	113	330			
14	350	762	584	413	54.0	1.6	514.5	20	32	-	575	630	153	370			
16	400	838	648	470	57.2	1.6	571.5	20	35	-	615	560	113	360			
18	450	914	711	533	60.4	1.6	628.5	24	35	-	725	630	153	420			
20	500	991	775	584	63.5	1.6	686.0	24	35	-	829	800	235	552			
24	600	1143	914	692	69.9	1.6	812.8	24	41	-	885	900	281	602			

TEFLON SLEEVED PLUG VALVES

P260 Flanged ANSI class 600

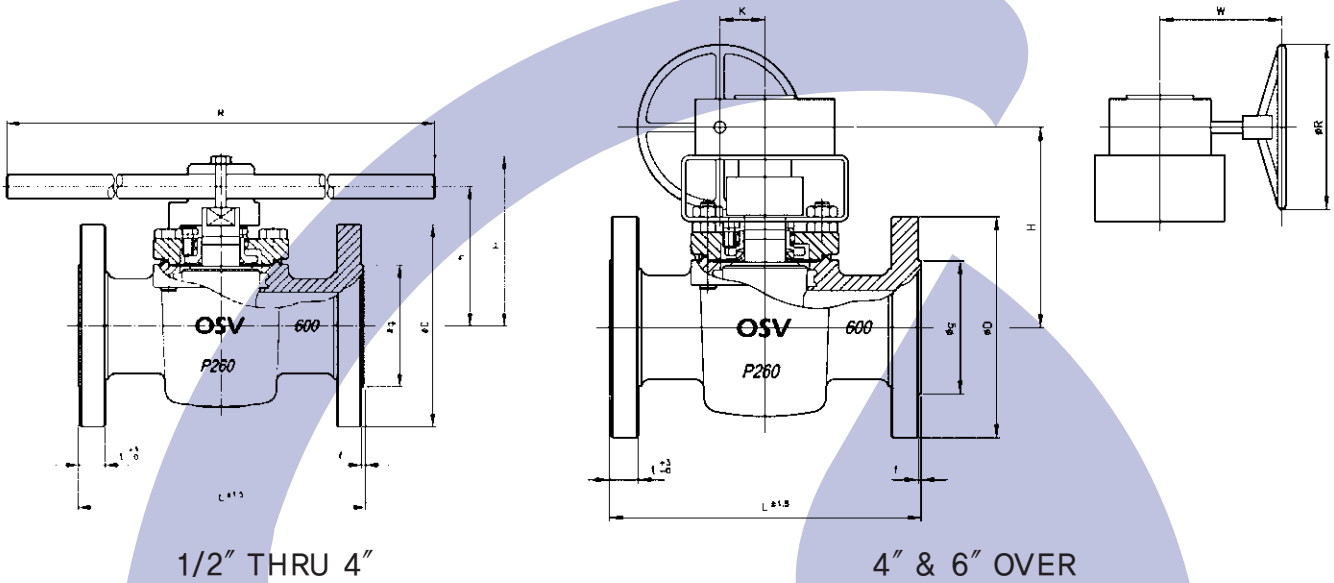

DIMENSIONS

UNIT : MM

IN	MM	L	END FLANGES				BOLT HOLE				h	H	R	K	W	OPERATOR	REMARK
			D	g	t	f	PCD	N	d								
1/2	15	165	95	35	20.7	6.4	66.5	4	16	80	-	180	-	-	WITH		
3/4	20	190	117	43	22.3	6.4	82.5	4	19	80	-	180	-	-			
1	25	216	124	51	23.9	6.4	89.0	4	19	75	96	222	-	-			
1.1/2	40	241	156	73	28.7	6.4	114.5	4	22	91	116	320	-	-			
2	50	292	165	92	31.8	6.4	127.0	8	19	106	130	460	-	-			
2.1/2	65	330	190	105	35.0	6.4	149.0	8	22	121	145	600	-	-			
3	80	356	210	127	38.1	6.4	168.0	8	22	121	145	600	-	-			
4	100	432	273	157	44.5	6.4	216.0	8	25	150	178	750	-	-			
4	100	432	273	157	44.5	6.4	216.0	8	25	-	233	250	53	177	WITH		
6	150	559	356	216	54.1	6.4	292.0	12	29	-	260	300	62.5	228	WORM		
8	200	660	419	270	62.0	6.4	349.0	12	32	-	343	300	62.5	228	GEAR		
10	250	787	508	324	69.9	6.4	432.0	16	35	-	374	500	91.5	297			
12	300	838	559	381	73.1	6.4	489.0	20	35	-	464	560	113	330			

NOTES

1. Pressure 900# and above size 12 inch of 600# and above 900#, 1500#, 2500# should be made case by case.
2. JIS standard table drawing will be released by OSV separately, when required by the client.

TEFLON SLEEVED JACKETED PLUG VALVES

Non-Lubricated

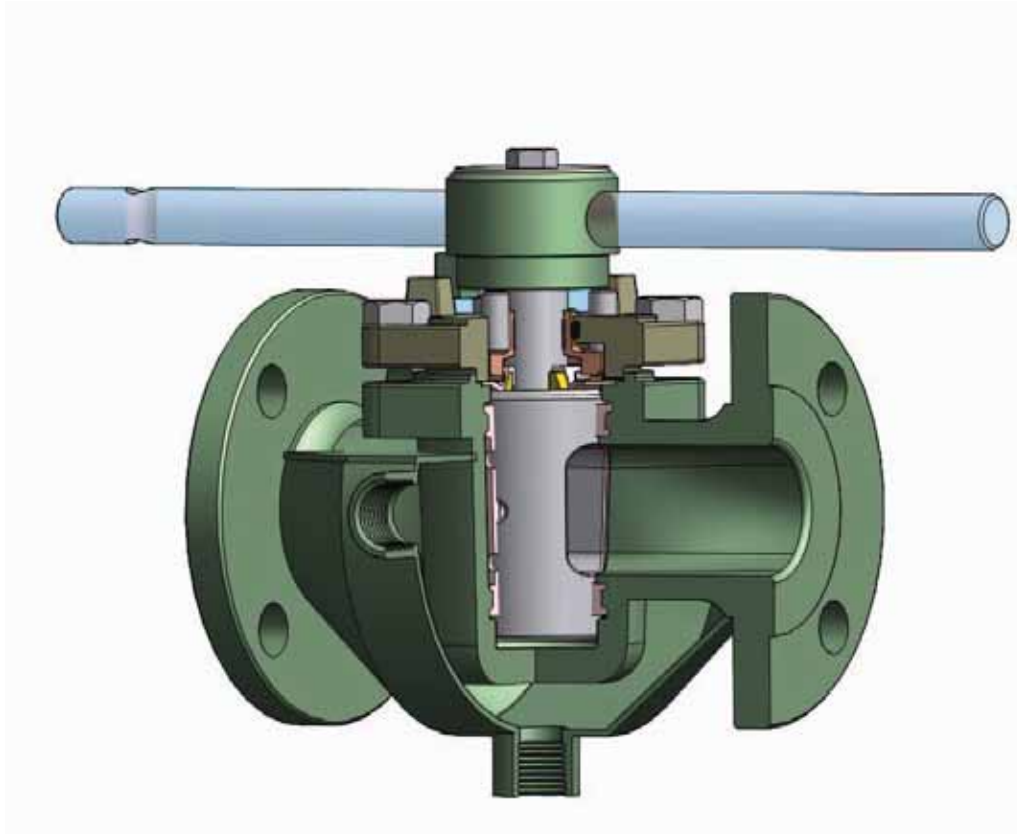

FIG. P250PJ 316/316/304
TEFLON SLEEVED JACKETED PLUG VALVES

Non-Lubricated Type

Jacket Type Partical Jacket, Full Jacket

Material - Body, Plug

WCB, LCB, 304, 304L, 316, 316L, A20, CD4M, HB, HC, MO, INCONEL, TI, ZR

Sleeve Material - PTFE, RTFE(GLASS, BRASS, GRAPHITE), TFM

Jacket Carbon Steel, Stainless Steel

Size 1/2" ~ 24"

Use Temperature -50℃~230℃

MULTI PORT TEFLON SLEEVED PLUG VALVES

Non-Lubricated



3-Way PLUG VALVES

FORM	A	AX	D	C	I	T	L
FLOW							
POSITION 1 0°							
POSITION 2 90°							
POSITION 3 180°							
POSITION 4 270°							

3-Way Port arrangement



4-Way PLUG VALVES

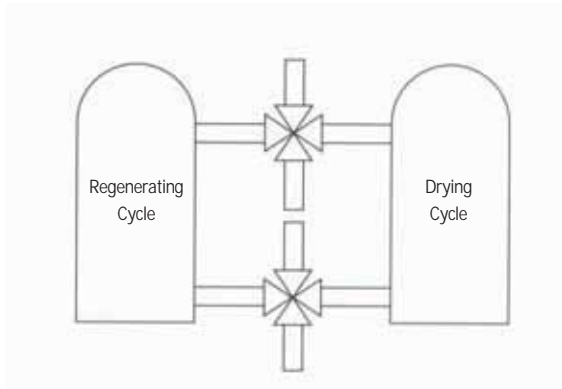

5-Way PLUG VALVES

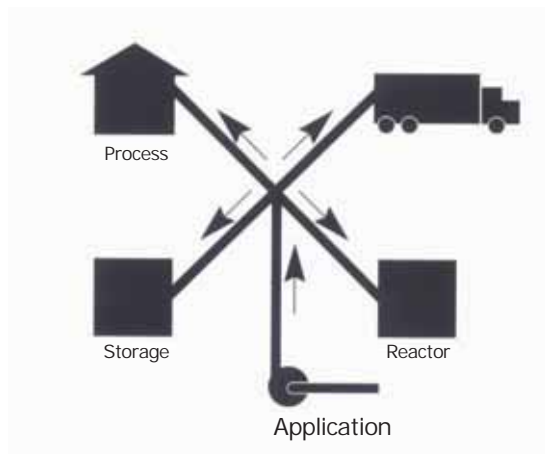

SCREW & WELD ENDS TEFLON SLEEVED PLUG VALVES

Non-Lubricated

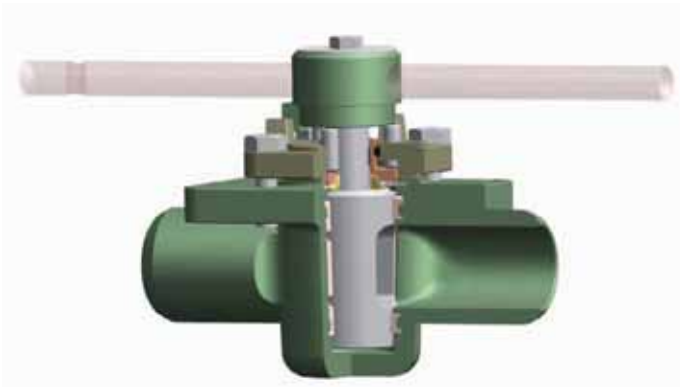

FIG. P260N BW 316/316
 BUTT WELD ENDS NUCLEAR PLUG VALVES
 2-WAY CLASS 150#, 300#, 600#
 JIS 10K, 20K, 40K
 1/2" ~ 8"



FIG. P250SC 316/316
 SCREW ENDS PLUG VALVES
 2-WAY, CLASS 150#, 300#, 600#
 JIS 10K, 20K, 40K
 1/2" ~ 2"



FIG. P250SW 316/316
 SOCKET WELD PLUG VALVES
 2-WAY, CLASS 150#, 300#, 600#
 JIS 10K, 20K, 40K
 1/2" ~ 8"



FIG. P250BW 316/316
 BUTT WELD ENDS PLUG VALVES
 2-WAY, CLASS 150#, 300#, 600#
 JIS 10K, 20K, 40K
 1/2" ~ 12"

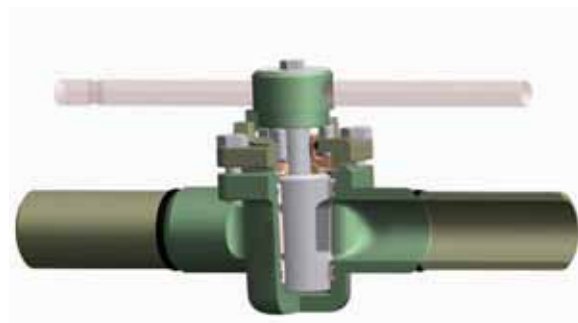

FIG. P250BW 316/316
 PUPS WELD ENDS PLUG VALVES
 2-WAY, CLASS 150#, 300#, 600#
 JIS 10K, 20K, 40K
 1/2" ~ 12"

EXTENDED PLUG VALVES

Non-Lubricated



FIG. P250EP WCB/316

EXTENDED PACKING TYPE PLUG VALVES

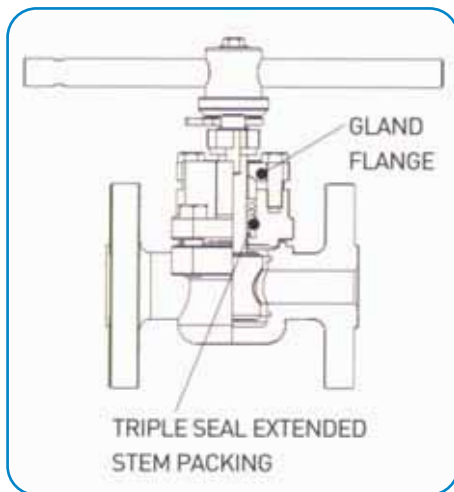

◆ Feature

- Extended triple seal stem packing type. Easy to choose the kinds and material of packing. (Graphite, PTFE V-Packing, VOC packing etc.)
- Leakproof semi-permanent structure though equally pressured Triple Seal Stem Packing by Gland flange.
- Various and steady Leaking Prevention by Steam Sealing.
- Usable as Live Loaded Extended Packing by using Plate
- Spring with an Option to use Gland Flange Bolt to do triple sealing against varying temperatures effectively.
- Able to prevent stern requirements for leaking prevention and control the requirements for sealing economically.

◆ Advantages

1. Completely No Leakage.

- ① As the tapered Plug and Teflon Sleeve contact face to face, it gives absolutely no leakage.
- ② A Steam Seal Structure has been designed to complement the controversial point of other plug valves.
- ③ As the Steam Seal is not exposed externally it doesn't rust/oxidate and is able to increase life span. (Weather Proof Type)

2. No Dead Space

No dead space in the fluid way can allow full control of open/close function and gives semi-permanent life span.

3. Few Maintenance and Repair needed

- ① No dead space is present, which prevents fluid to be clogged up.
- ② Re-adjusting of Seal Pressure by using Adjusting-Bolt After abrasion of Teflon Sleeve gives semi-permanent sealing function
- ③ Metal lib around the Port has a Self-Cleaning function to control steamy and solid material liquid.
- ④ Top Entry type gives the possibility to be repaired on-line.

METAL SEATED PLUG VALVES

Non-Lubricated Type

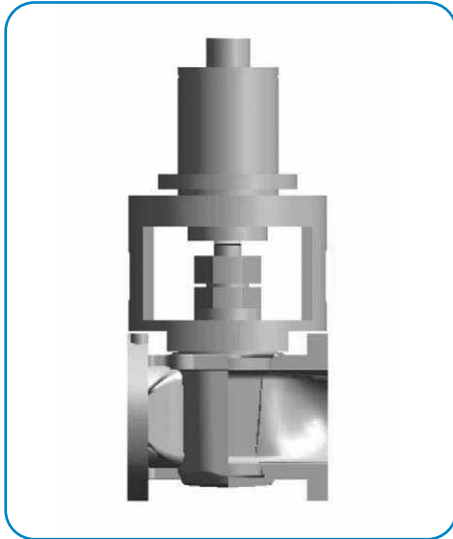

FIG. P250M 316/316
METAL SEATED PLUG VALVES

OSV METAL SEATED PLUG VALVES

- **Non-Lubricated Lift & Turn Type**
- **Type** Standard Bore
- **Material** Body, Plug : 304, 304L, 316, 316L, A20, CD4M, MONEL
- **Size** 1/2" ~ 12"
- **Class** ANSI #150, 300, 600
JIS 10K, 20K, 40K
- **Temperature** below -50°C, 300°C ~ 700°C
- **End Connection** SCR(PT, NPT), BW, SW, FF, RF, LMF, T&G
- **Use**

High and Low temperature like PA, RFCC, Heat Medium, Tar, LPG or the place which needs Zero Leakage, Zero Maintenance eith Fire Safe function required Process.

◆ Feature

- **Structure** : Similar with Sleeve type Plug valves but like Lined Type

1) Operation with No Leakage, 2) No Dead-Space, 3) No Maintenance

- **Non Lubricate type**

This is a Non-Lubricate type, Metal seat type. Therefore it doesn't need Lubricant. Also it is able to prevent any contamination in Line which is available to manege line clearly. Putting tapered metal plug in to Metal seat (which was nestled in the body) can achieve perfect sealing. Opening the valve is done by lifting Tapered plug up slightly and turn in one quarter. Valve closure is done in the reverse way of opening the valve, which is operated by unique mechanism. Thus operation doesn't need any force and makes open and closure available absolutely anytime. OSV also has Trunnion type plug valves which attain our product range wide.

- **Credibility of basic sealing** : different with ball valves, since Plug valves form sealing by mechanical structure and equipments, plug valves aren't affected by line pressure at all.

Tapered plug prevents absolutely all leakage without a valve bonnet in a wat similar to a cork stopper of wine. This means absolute zero leakage. Since ball valves don't have a basic sealing by there structure, they are rather weak for leakage problems with its floating system.

- **Application for high and low temperature.** OSV Metal Seated Valve can easily apply to high and low temperature. Selecting adequate valve material for specific temperature conditions should be consulted with OSV

- **Application for high pressure and high vacuum fluid.** OSV plug valves, including but not limited to OSV Metal Seated Valves, have a perfect sealing system. Any other metal valves including ball valves can assure zero leakage at all. To review detail advantages of OS valves, please refer to OSV Teflon Sleeved Plug Valves or Teflon Lined Valves explanations.

OSV PLUG VALVES for OPERATING TORQUE

1. PURPOSE

The purpose of this procedure is to prescribe allowable Break torque, Running torque and Seating torque for On-Off operation by measuring of working rate of PTFE Sleeved Plug Valves.

2. SCOPE

This procedure is applicable to the OSV Sleeved Plug Valve from 1/2" to 18"

3. ALLOWABLE TORQUE

VALVE SIZE	BREAK TORQUE		RUNNING TORQUE		SEATING TORQUE		REMARKS
	IN · LBS	KG · M	IN · LBS	KG · M	IN · LBS	KG · M	
1/2"	140	1.6	70	0.8	80	0.9	
3/4"	140	1.6	70	0.8	80	0.9	
1"	400	4.6	200	2.3	250	2.9	
1.1/2"	800	9.2	400	4.6	500	5.8	
2"	1100	12.8	550	6.4	650	7.5	
3"	1200	13.8	600	6.9	700	8	
4"	2400	27.6	1200	13.8	1450	16.7	
6"	5000	57.6	2500	28.8	3000	34.5	
8"	7800	89.9	3900	44.9	4700	54.1	
10"	14400	165.8	7200	82.9	8600	98.9	
12"	21000	241.6	10500	120.8	12600	144.9	
14"	(32600)	(365.6)	(16300)	(181.3)	(19500)	(224.3)	
16"	(65300)	(725.2)	(32600)	(362.6)	(39000)	(448.9)	
18"	(130000)	(1450.1)	(65000)	(725.2)	(78000)	(879.0)	



TEFLON LINED PLUG VALVES

TEFLON LINED PLUG VALVES

Non-Lubricated

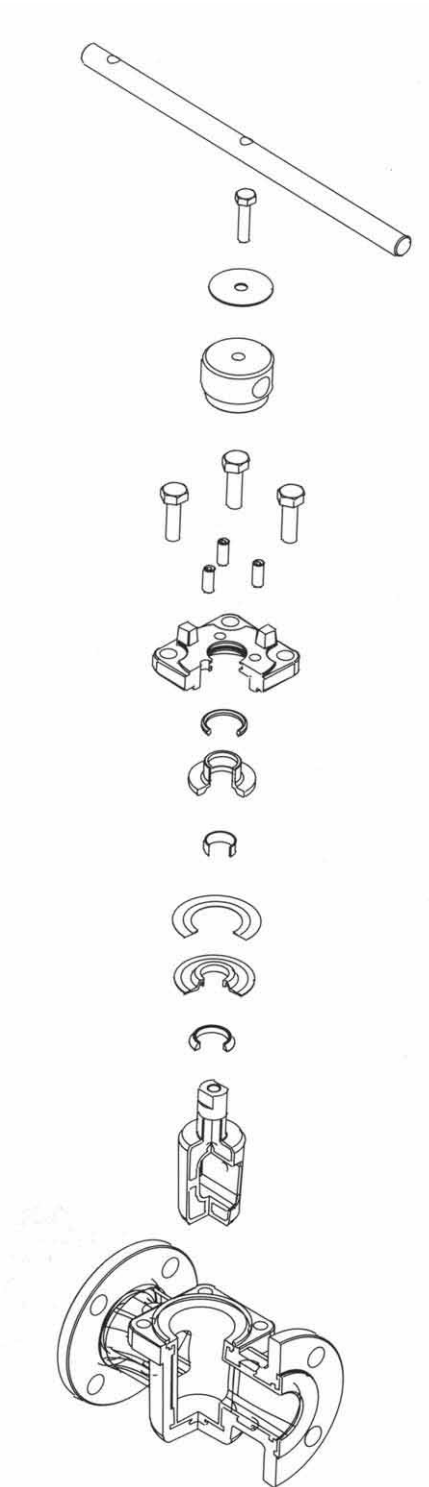

■ PART OF STANDARD MATERIAL

NO	DESCRIPTION	MATERIAL	SPECIFICATION
1	WRENCH	CARBON STEEL	1045. PAINTED
2	HUB BOLT	CARBON STEEL	SUS304
3	NAME PLATE	STAINLESS STEEL	SUS304
4	HUB	CARBON STEEL	ASTM A216 WCB
5	COVER BOLT	STAINLESS STEEL	ASTM A193 B7
6	ADJUSTING BOLT	STAINLESS STEEL	SUS304
7	COVER	CARBON STEEL	ASTM A216 WCB
8	O-RING	VITON	
9	THRUST COLLAR	STAINLESS STEEL	SUS304
10	ANSTATIC BEARING	RTFE	
11	METAL DIAPHRAGM	STAINLESS STEEL	SUS304
12	PTFE DIAPHRAGM	RTFE	
13	WEDGE RING	RTFE	
14	PLUG	CAST STL PFA LINED	ASTM A216 WCB
15	BODY	CAST STL PFA LINED	ASTM A216 WCB

TEFLON LINED PLUG VALVES

Non-Lubricated

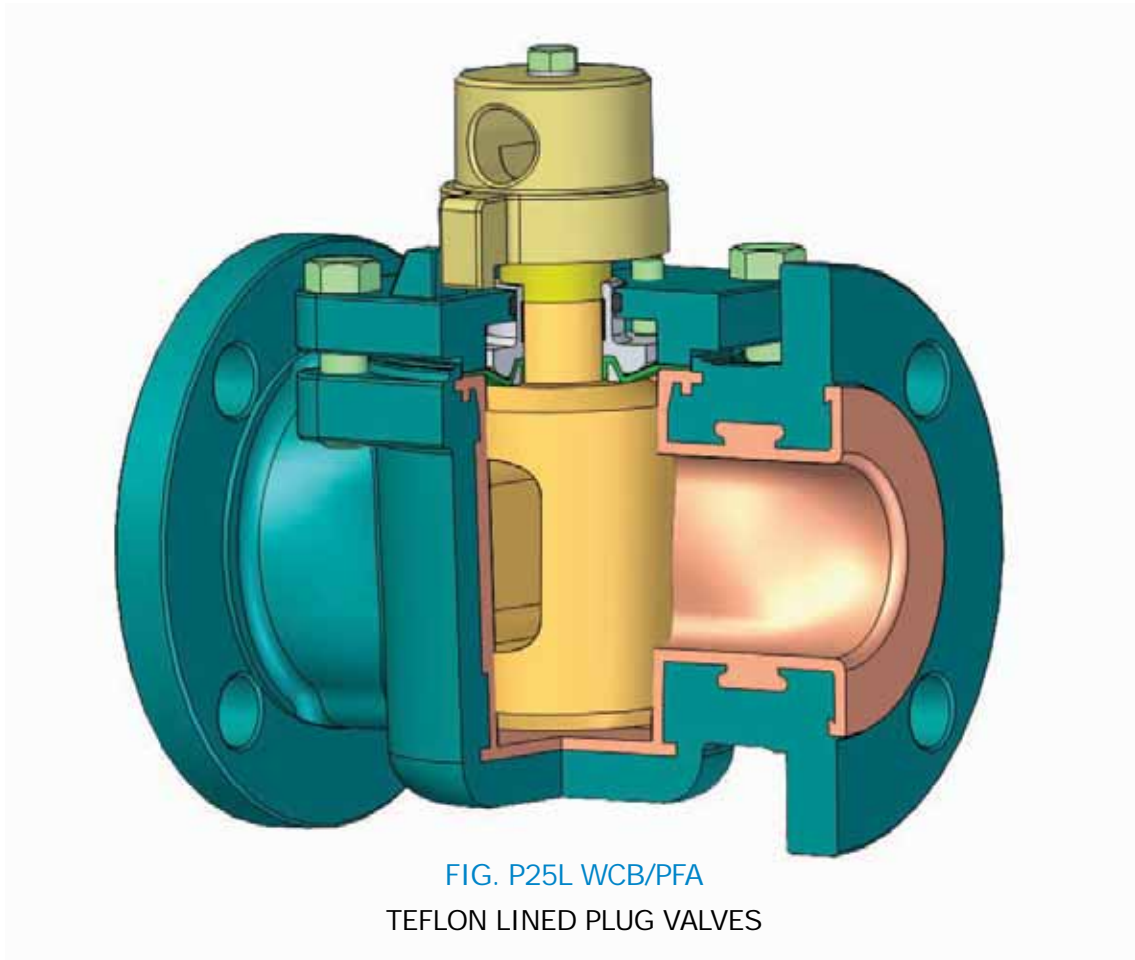

FIG. P25L WCB/PFA
TEFLON LINED PLUG VALVES

Non-Lubricated Type

Material

- Body, Plug : ASTM A216 WCB, ASTM A351 CF8M, CF3M, ETC

- LINING MATL: PFA

Size 1/2" ~ 18"

Use Temperature -50℃ ~ 230℃

Main Fluid : Acidic or Alkatic fluid line specially required for No-Leakage.

TEFLON LINED PLUG VALVES

P25L Flanged ANSI class 150

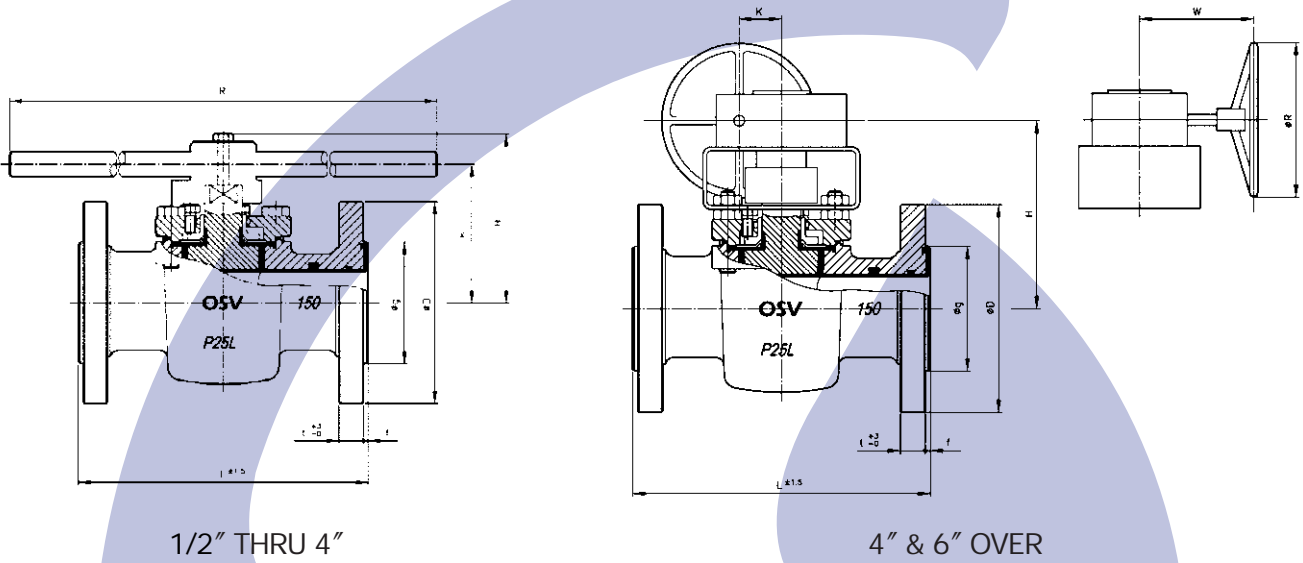

DIMENSIONS

UNIT : MM

IN	MM	L	END FLANGES				BOLT HOLE			h	H	R	K	W	OPERATOR	REMARK
			D	g	t	f	PCD	N	d							
			1/2	15	108	89	35	11.7	2.0							
3/4	20	117	98	43	12.4	2.0	70.0	4	16	80	-	180	-	-		
1	25	127	108	51	14.2	3.0	79.5	4	16	75	96	222	-	-		
1.1/2	40	165	127	73	17.2	3.0	98.5	4	16	91	116	320	-	-		
2	50	178	152	92	18.8	3.0	120.5	4	19	106	130	460	-	-		
2.1/2	65	190	178	105	20.5	3.0	139.5	4	19	121	145	600	-	-		
3	80	203	190	127	22.1	3.0	152.5	4	19	121	145	600	-	-		
4	100	229	229	157	27.4	3.5	190.5	8	19	150	178	750	-	-		
4	100	229	229	157	27.4	3.5	190.5	8	19	-	233	250	53	177	WITH WORM GEAR	
6	150	267	279	216	28.9	3.5	241.5	8	22	-	260	300	62.5	228		
8	200	292	343	270	32.1	3.5	298.5	8	22	-	343	300	62.5	228		
10	250	330	406	324	34.2	4.0	362.0	12	25	-	374	500	91.5	297		
12	300	356	483	381	35.8	4.0	432.0	12	25	-	464	560	113	330		

TEFLON LINED PLUG VALVES

P23L Flanged ANSI class 300

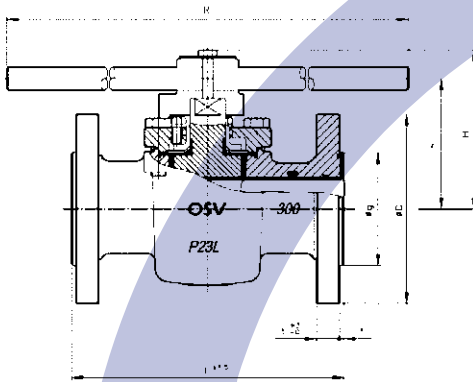

1/2" THRU 4"

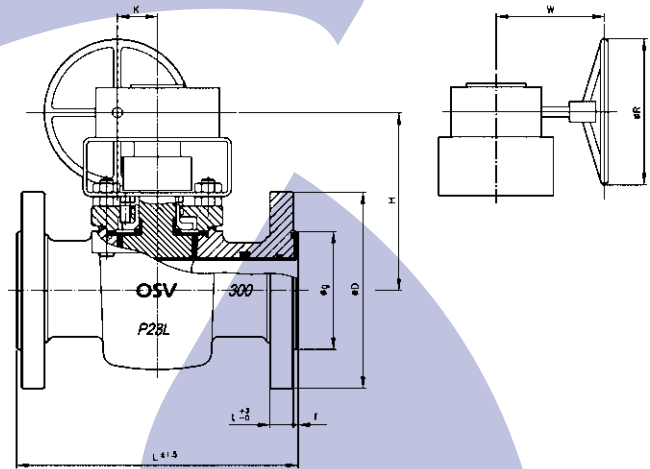

4" & 6" OVER

DIMENSIONS

UNIT : MM

IN	MM	L	END FLANGES							h	H	R	K	W	OPERATOR	REMARK
			D	g	t	f	BOLT HOLE									
							PCD	N	d							
1/2	15	140	95	35	16.3	2.0	66.5	4	16	80	-	180	-	-	WITH	
3/4	20	152	117	43	17.9	2.0	82.5	4	19	80	-	180	-	-	WRENCH	
1	25	165	124	51	20.5	3.0	89.0	4	19	75	96	222	-	-		
1.1/2	40	190	156	73	23.7	3.0	114.5	4	22	91	116	320	-	-		
2	50	216	165	92	25.3	3.0	127.0	8	19	106	130	460	-	-		
2.1/2	65	283	210	127	31.6	3.0	168.0	8	22	121	145	600	-	-		
3	80	305	254	157	35.3	3.5	200.0	8	22	121	145	600	-	-		
4	100	305	254	157	35.3	3.5	200.0	8	22	150	178	750	-	-		
4	100	403	318	216	39.1	3.5	270.0	12	22	-	233	250	53	177	WITH	
6	150	419	381	270	46.8	3.5	330.0	12	25	-	260	300	62.5	228	WORM	
8	200	457	444	324	52.2	4.0	387.0	16	29	-	343	300	62.5	228	GEAR	
10	250	502	521	381	54.8	4.0	451.0	16	32	-	374	500	91.5	297		
12	300	140	95	35	16.3	2.0	66.5	4	16	-	464	560	113	330		



TEFLON LINED ACCESSORY VALVES

TEFLON LINED BALL CHECK VALVES

Non-Lubricated

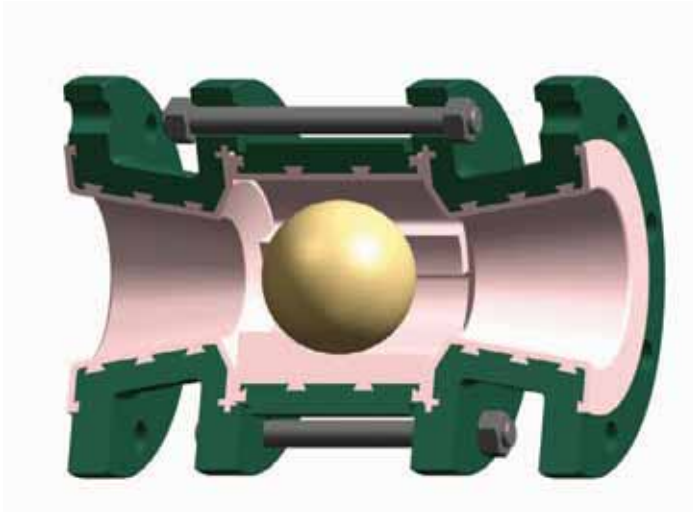
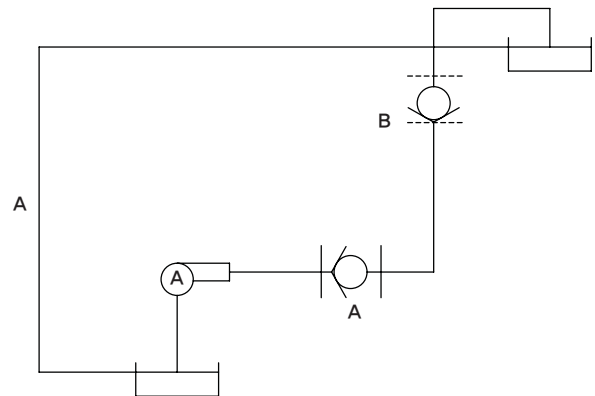

FIG. B25L WCB/PFA
TEFLON LINED BALL CHECK VALVES



OPERATION DIAGRAM

► Structure

The whole body of the valve has PFA & FEP Teflon linings. RTFE ball moves freely on the Spacer where lining has been done with Teflon materials and the ball stops in the double sided flange passage way. Pressure of the material of the counter flow moves the ball upstream stopping the flow. The spacer of the downstream is in development to ensure there is a free flow.

Places of use and function

- 1) Prevent harm done on the pump motor by counter flow
- 2) Prevent harm done on the pump impeller by the counter flow
- 3) Interception when the back-head is high

TEFLON LINED BALL CHECK VALVES

B25L Flanged ANSI class 150

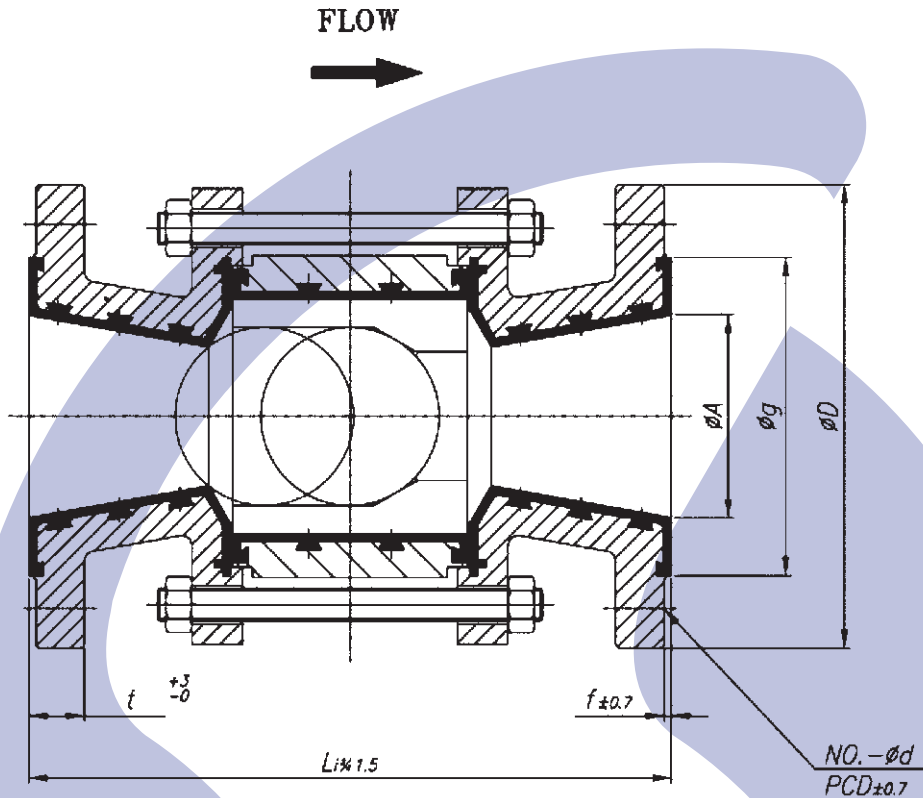

DIMENSIONS

UNIT : MM

NOMINAL SIZE		END FLANGES									WALL THICKNESS	WEIGHT (KG)	ACTUATOR	REMARK
IN	MM	L	D	A	g	t	f	BOLT HOLE						
								PCD	NO.	d				
1/2	15	152	89	15	35	10.1	2.0	60.5	4	16	6.4	3	BALL CHECK TYPE	
3/4	20	152	98	20	43	10.8	2.0	70.0	4	16	6.4	3.5		
1	25	152	108	25	51	12.6	3.0	79.5	4	16	6.4	4		
1.1/2	40	165	127	38	73	15.6	3.0	98.5	4	16	6.4	10		
2	50	217	152	51	92	17.2	3.0	120.5	4	19	8.7	15		
3	80	254	190	76	127	20.5	3.0	152.2	4	19	10.3	22		
4	100	317	229	102	157	25.8	3.5	190.5	8	19	11.1	378		
6	150	381	279	152	216	27.3	3.5	241.5	8	22	11.9	50		
8	200	482	343	203	270	31.2	3.5	298.5	8	22	12.7	85		
10	250	635	406	250	324	34.2	4.0	362.0	12	25	14.3	127		

TEFLON LINED SWING CHECK VALVES

Non-Lubricated



FIG. S25L WCB/PFA
TEFLON LINED SWING CHECK VALVES

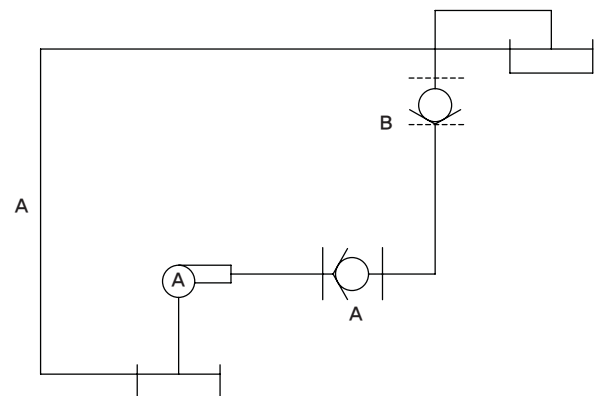

OPERATION DIAGRAM

► Structure

Teflon Lined Swing Check Valve is composed of the Body and 2 Discs all of which come in contact with the flowing bodies. The areas of contact have Teflon lining making the product applicable to places where an anti-corrosive characteristic is needed instead of high steel alloy valves. The disc with an attached hinge between the valve's body and the flange moves to stop or allow the flow.

Use

- 1) Prevention of the counter rotation of the Pump Motor
- 2) Shock prevention of the Pump
- 3) Shut-off function when the back head is high

TEFLON LINED SWING CHECK VALVES

Non-Lubricated



► Use

- Vertical and horizontal piping can be available.
- It can be with strong and corrosive liquid instead of an expensive high-alloy valve.
- It has only its own two components since a spring or pin can't be used because of corrosion and oxidation.

► Material

Body	WCB(316) / PFA(FEP)
DISC	FEP(PFA) : 4" and Under
	WCB/PFA(FEP) : 6" and Under
	LINING THICK 2.4mm Over

TEFLON LINED WATER TYPE CHECK VALVES

S25L Flanged ANSI class 150

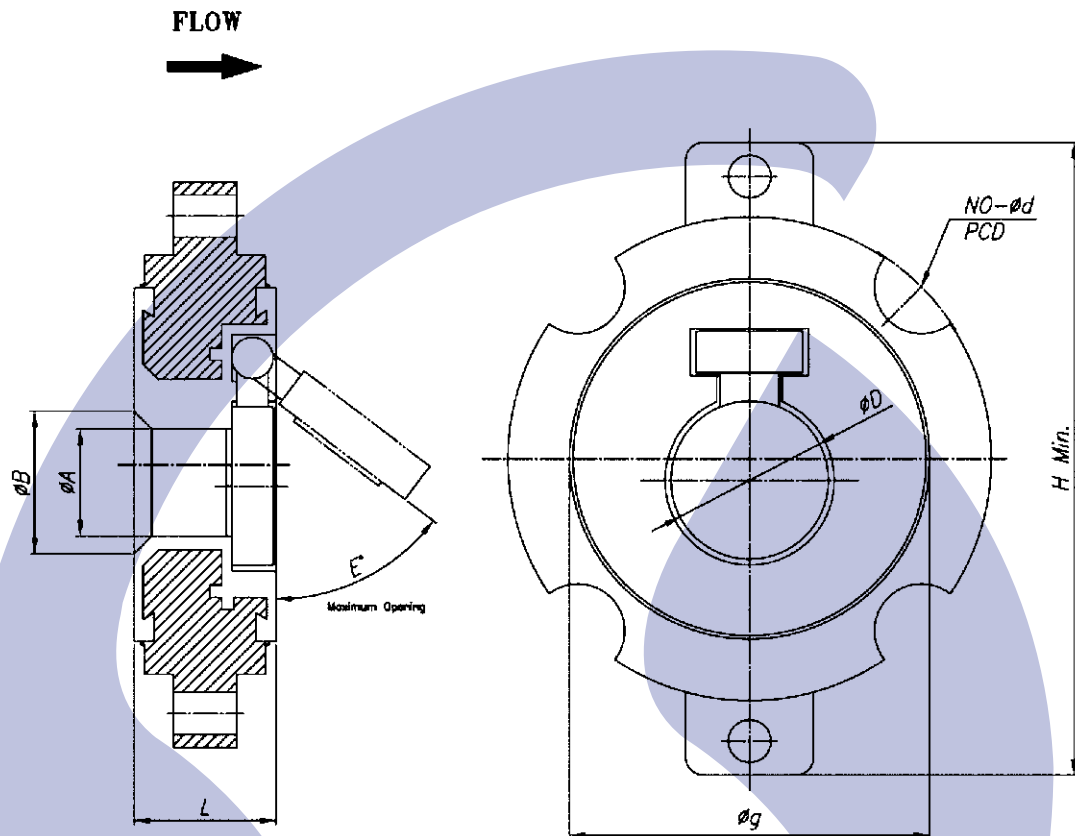

DIMENSIONS

UNIT : MM

NOMINAL SIZE		L	g	END FLANGES			A	B	E	H	REMARK
IN	MM			BOLT HOLE							
				PCD	NO.	d					
1.1/2	40	40	73	98.5	4	16	25	36	51	105	
2	50	40	92	12.5	4	19	30	40	53	175	
3	80	46	127	152.5	4	19	45	55	55	190	
4	100	46	157	190.5	8	19	70	80	64	266	
6	150	57	216	241.5	8	22	110	125	65	319	
8	200	67	270	298.5	8	22	158	172	61	373	
10	250	76	324	362.0	12	25	184	222	53	394	
12	300	86	381	432.0	12	25	232	256	53	510	



METAL TYPE LUBRICATED PLUG VALVES

METAL TYPE PRESSURE BALANCED PLUG VALVES

Lubricated

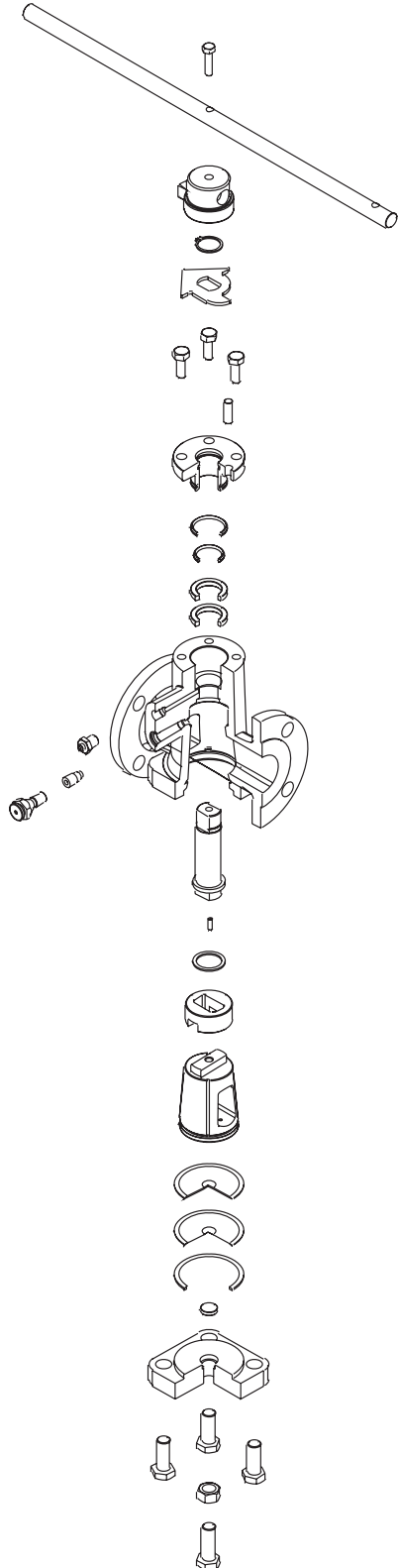

■ PART OF STANDARD MATERIAL

NO	DESCRIPTION	MATERIAL	SPECIFICATION
1	WRENCH	CARBON STEEL	1045. PAINTED
2	HUB BOLT	CARBON STEEL	SUS304
3	HUB	CARBON STEEL	ASTM A216 WCB
4	SNAP RING	CARBON STEEL	1020, PAINTED
5	INDICATOR	STAINLESS STEEL	SUS304
6	STEM	STAINLESS STEEL	SUS316
7	THRUST BEARING	STAINLESS STEEL	SUS316
8	GRAND BOLT	STAINLESS STEEL	SUS304
9	STOPPER	STAINLESS STEEL	SUS304
10	GRAND	STAINLESS STEEL	SUS316
11	GRAND PACKING	GRAPHITE	
12	O-RING(I)	VITON	
13	O-RING(II)	VITON	
14	BODY	CARBON STEEL	ASTM A216 WCB
15	NEEDLE VALVE	STAINLESS STEEL	SUS304
16	CHECK VALVE	STAINLESS STEEL	SUS304
17	GREASE NIPPLE	STAINLESS STEEL	SUS304
18	COMPENSATOR	CARBON STEEL	1045 PAINTED
20	METAL DIAPHRAGM(I)	STAINLESS STEEL	SUS304
21	METAL DIAPHRAGM(II)	CARBON STEEL	1045
22	GASKET	SOFT STEEL	1020
23	PRESSURE BUTTON	CARBON STEEL	ASTM A216 WCB
24	COVER	CARBON STEEL	ASTM A216 WCB
25	COVER BOLT	CARBON STEEL	ASTM A193 B7
26	LOCK NUT	CARBON STEEL	ASTM A194 2H
27	ADJUSTING BOLT	CARBON STEEL	ASTM A193 B7

METAL TYPE PRESSURE BALANCE PLUG VALVES

Lubricated

DESIGN FEATURES

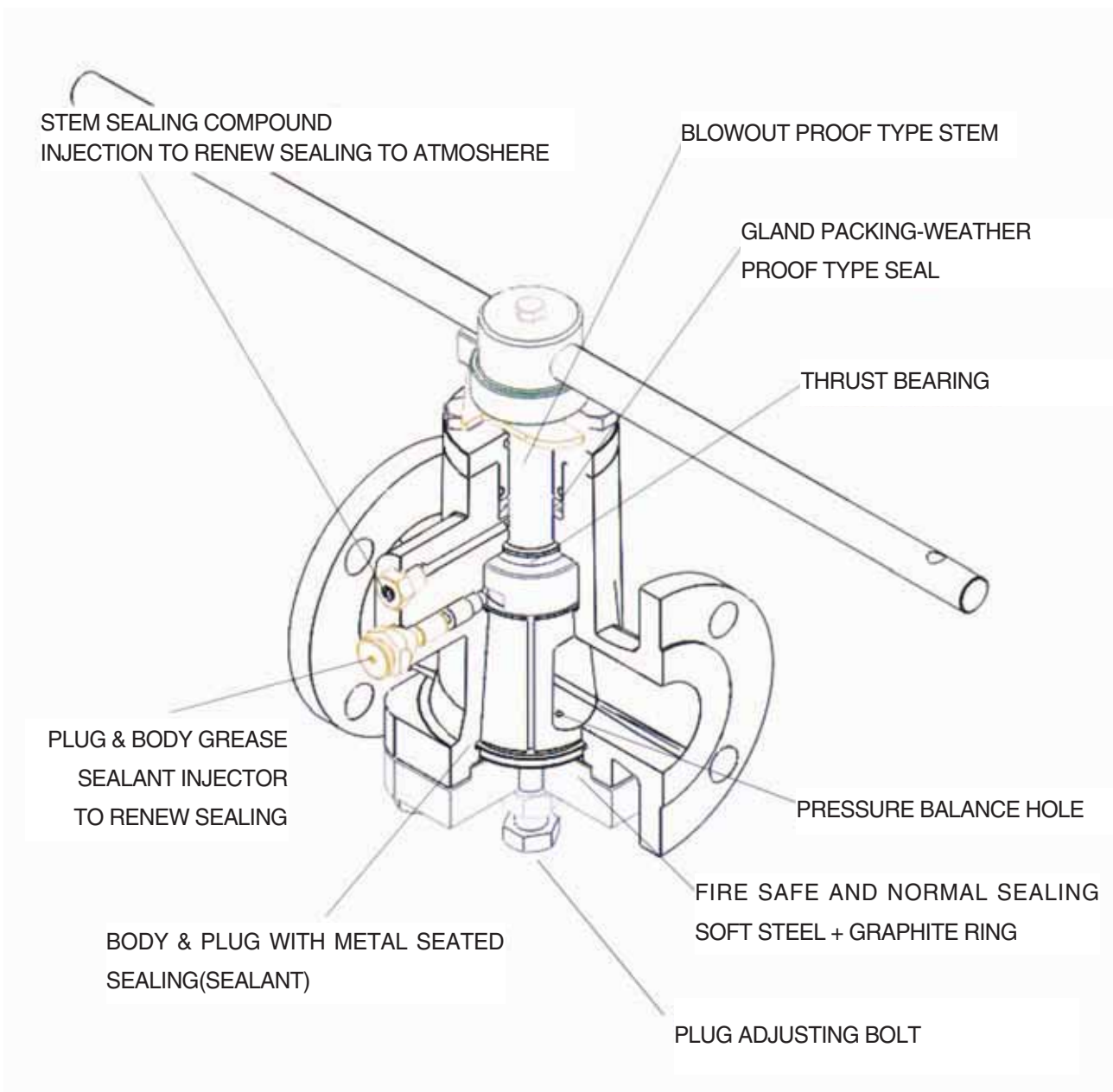

METAL TYPE PRESSURE BALANCE PLUG VALVES

Lubricated

■ FEATURES

1. OSV FEATURES

1) No Leakage (Bubble Tight Shut Off)

OSV tapered plug valve assures positive bubble tight shut off with unique sealant system.

2) No Maintenance (In-Line Adjustment)

OSV tapered plug valve can be adjusted with the valve in line, extending the service life of the valve.

3) No Dead Space

Slurry or sludge don t accumulate anywhere in a OSV valve, because OSV valve have no dead cavity in the flow path.

2. EASE OF OPERATION

Positive quarter turn operation is quick and sure.

3. PRESSURE BALANCE SYSTEM

For maintaining pressure equalization between plug port and bottom of the plug, and for ensuring the pressure above the plug being the same as or greater than in the plug port, OSV pressure balance system design is available.

4. SAFETY

Fire tested according to API 607.

■ BENEFIT

1. PRESSURE BALANCED TYPE AS STANDARD

2. BLOWOUT- PROOF STEM STRUCTURE

3. OPERATION

1) Freedom from seizure by long service operation

2) Consistent Torque

4. SELF CLEANING SEATING SURFACE

The turning action of plug valves scrape off any ingredient which may accumulate the plug surface in a closed position.

METAL TYPE PRESSURE BALANCED PLUG VALVES

Lubricated

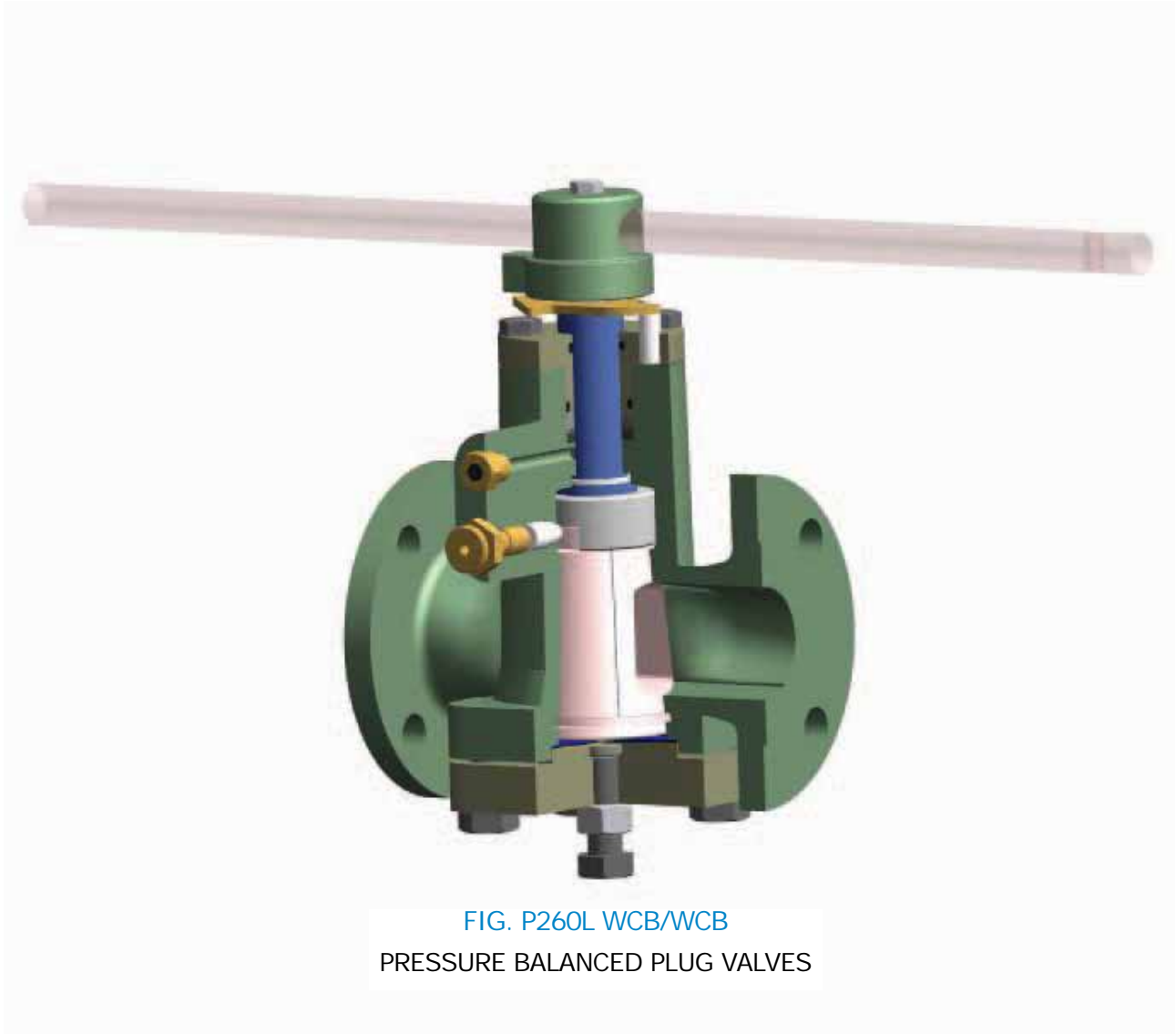

FIG. P260L WCB/WCB
PRESSURE BALANCED PLUG VALVES

Lubricated Type

- ▶ CLASS ANSI 150#, 300#, 600#, 900#, 1500#
- ▶ Size 1/2" ~ 24"

METAL TYPE PRESSURE BALANCE PLUG VALVES

Lubricated Type

SEALANTS

OSV	ROCKWELL	WALWORTH	CLIMAX	AVAILABLE FLUID
OS-400/400A	147-421		400/400A	Acids, Alcohols, Glycerine
OS-204	234		204	Silicone sealant
OS-711	357		711	Gasoline, Mineral Oils, Kerosene
OS-600	386		600	General gas and Water sealant
OS-650/800/900	555	No.1	650/800/900	Aliphatic hydrocarbon liquids and gases
OS-650/800/900	654		650/800/900	Hot hydrocarbon vapors and gases
OS-711	755	No.7	711	Benzene, butane, solvent naphthas
OS-711	833		711	Aviation gasoline, Jet fuel
OS-GP	862		220	Air and inert gases at sub-zero temp
OS-950	950	No.5, No6	950	Benzene, propylene, styrene, LPGS
OS-400A		No.4	400A	Strong acids, alkalies
OS-340			340	Sour gas, H ₂ S, CO ₂
OS-FL5	660		FL-5	Fluorocarbon, lubricant oxygen chlorine
OS-PS3	921		Polyseal No.3	Hot hydrocarbon gases and vapors
OS-PS6		No.2	Polyseal No.6	Steam, high temperature water

The available fluid is recommended by OSV. As the conditions of the used fluid differ, it is possible to change the appropriate sealant.

METAL TYPE PRESSURE BALANCE PLUG VALVES

Lubricated Type

APPLICATION : CHEMICAL, OIL, GAS AND HYDROCARBON PROCESS IN INDUSTRIES

OSV PATTERN FOR PRESSURE BALANCED PLUG VALVES.

1. OSV HAVE CAST PATTERNS FOR SHORT, REGULAR AND VENTURI ACCORDING TO API 6D & API599.
2. FACE TO FACE AND END TO END DIMENSIONS CONFORM TO API599 (ANSI B 16.34).
3. AVAILABLE PATTERN GOING WITH SIZE & CLASS.

NORMAL SIZE		CLASS			
IN	MM	ANSI 150#	ANSI 300#	ANSI 600#	ANSI 1500#
1/2	15			R R	
3/4	20			R R	
1	25			R R	
1-1/2	40		S	R R	
2	50	S	S	R R	
3	80	S	S	R R	
4	100	S	S	R R	
6	150	S	V	R V R	V
8	200	S	V	R V R	V
10	250	S	V	R V R	V
12	300	S	V	R V R	V
14	350	V	V	R V	
16	400	V	V	V	V
18	450	V	V	V	
20	500	V	V	V	
24	600	V	V	V	

NOTES

1. Above pattern is available for flanged end type.
2. If a Specific requirement for pattern is available, please contact to OSV
3. Above chart symbols means as follows :
S : SHORT PATTERN, R : REGULAR PATTERN, V : VENTURI PATTERN

METAL TYPE PRESSURE BALANCE PLUG VALVES

Lubricated Type

LUBRICANTS

The role of lubricants

It minimizes the resistance during working and prevents corrosion inside the plug. The port part of the valve is covered with lubricant groove and prevents any leakage.

The characteristic of lubricants

OSV-Lubricants have necessary characteristics for several purposes.

1. The lubricated valve is suitable for working the valve easily.
2. It is strong enough to resist dilution by fluids.
3. It is chemically inactive and firmly adherent for anti-corrosiveness .
4. It maintains a fluid state against a wide range of temperatures.
5. It minimizes the solidification caused by temperature or chemical reactions.

The selection of lubricants

It is selected in accordance with temperature, conformable and non-conformable fluids as below.

■ TABLE-1 OSV LUBRICANTS

LUBRICANT NO.	COLOR	TEMPERATURE	CONFORMITY	NON-CONFORMITY
OS-104	Peanut Butter	18~260°C	Scrayched ball & plug valve	Alkali
OS-204	White	46~204°C	Molten Sulfur, Acetic Anhydride, Acetic Acid	LPG or solvent of hydrocarbon
OS-220	Transparent	59~121°C	Pipe line, compressor, Gasoline & oil factory for Low temperature	Aromatic & sorbent
OS-340	Yellow	28~204°C	Where H ₂ and CO ₂ meet	Solvent & ammine
OS-350A	Yellow	29~204°C	Mixture of HF & LPG	High temperature air
OS-400A	Yellowish brown	29~204°C	Aqueous solution of acid & base	Fluid hydrocarbon
OS-400	Red	20~232°C	Acid & base	Fluid hydrocarbon
OS-525	Transparent	18~204°C	Air starting valve	Fluid hydrocarbon
OS-600	Brown	29~260°C	Gas & water Sealant & hydrocarbon line	LPG
OS-650	Green	40~260°C	Hydrocarbon & LPG line	Aromatic, alkali & sorbent
OS-711	White	0~204°C	Aerial Gasoline & oil, Alkylate compound	100% Benzine

METAL TYPE PRESSURE BALANCE PLUG VALVES

Lubricated Type

LUBRICANTS

LUBRICANT NO.	COLOR	TEMPERATURE	CONFORMITY	NON-CONFORMITY
OS-750	Black	18~316°C	High temperature asphalt line & steam line	Aromatic, alkali, sorbent
OS-800	White	29~232°C	Butane, Butadiene, CCL4, Ethane, Propane	Alkali
OS-900	Black	29~343°C	Natural gas, Oil-Chemical factory, Bubber Factory	Alkali
OS-901	Black	34~149°C	Low temperature air, Hydrocarbon lubricant	Alkali
OS-950	Black	40~149°C	Propylene, Butadiene Xylene, Benzene, Styrene	Alkali

LUBRICANT NO.	TEMPERATURE	CONFORMITY	NON-CONFORMITY
OS-Turn #1	29~260°C	Removal of residue in Hydrocarbon line valve	Sealant
OS-Turn #2	29~260°C	Ditto, except acid & base	Sealant
OS-FL5	18~204°C	Corrosive fluid & oxide	Aluminium & Magnesium
OS-PS6	0~232°C	Steam & high temperature water	Fluid hydrocarbon
OS-PS3	0~343°C	Over-heated steam	Fluid hydrocarbon
OS-1500	~815°C	Anti-Ceez Lubricant	Fluid hydrocarbon
OS-S3	29~177°C	EP bearing lubricant	Fluid hydrocarbon

The maintenance of lubricant

The needed quantity of maintenance shall be in accordance with the working cycle of the valve.

Periodical improvement

Leakage should be prevented. All valves that are not used periodically should be improved every six months.

LUBRICATED TYPE PLUG VALVES

P250L Flanged ANSI class 150

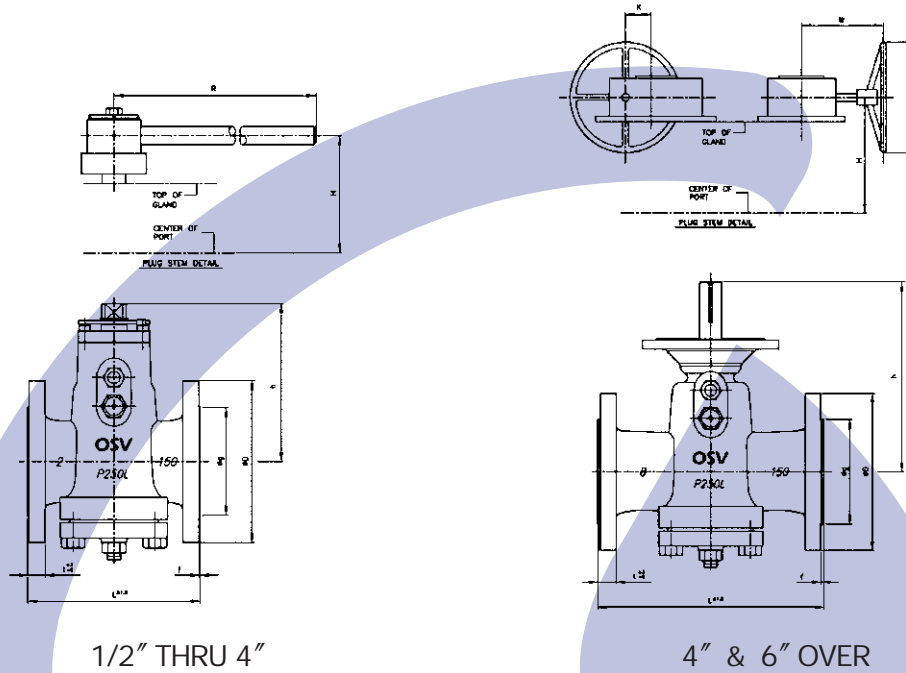

DIMENSIONS

UNIT : MM

IN	MM	L	END FLANGES							h	H	R	K	W	OPERATOR	REMARK
			D	g	t	f	BOLT HOLE									
							PCD	N	d							
1/2	15	108	89	35	9.7	1.6	60.	5	4	16	68	87	180	-	-	WITH WRENCH
3/4	20	117	98	43	10.4	1.6	70.0	4	16	68	87	180	-	-		
1	25	127	108	51	11.2	1.6	79.5	4	16	98	125	222	-	-		
1.1/2	40	165	127	73	14.2	1.6	98.5	4	16	148	168	320	-	-		
2	50	178	152	92	15.8	1.6	120.5	4	19	170	182	460	-	-		
2.1/2	65	190	178	105	17.5	1.6	139.5	4	19	205	225	600	-	-		
3	80	203	190	127	19.1	1.6	152.5	4	19	205	225	600	-	-	WITH WORM GEAR	
4	100	229	229	157	23.9	1.6	190.5	8	19	232	248	750	-	-		
4	100	229	229	157	23.9	1.6	190.5	8	19	232	248	250	53	177		
6	150	267	279	216	25.4	1.6	241.5	8	22	325	381	300	62.5	228		
8	200	292	343	270	28.6	1.6	298.5	8	22	382	465	300	62.5	228		
10	250	330	406	324	30.2	1.6	362.0	12	25	423	580	500	91.5	297		
12	300	356	483	381	31.8	1.6	432.0	12	25	483	645	560	113	330		
14	350	381	533	413	35.1	1.6	476.0	12	29	525	762	630	153	370		
16	400	762	597	470	36.6	1.6	539.5	16	29	735	814	560	113	360		
18	450	864	635	533	39.7	1.6	578.0	16	32	895	925	630	153	420		
20	500	914	698	584	42.9	1.6	635.0	20	32	945	1025	800	235	552		
24	600	1067	813	692	52.4	1.6	749.5	20	35	1020	1254	900	281	602		

LUBRICATED TYPE PLUG VALVES

P230L Flanged ANSI class 300

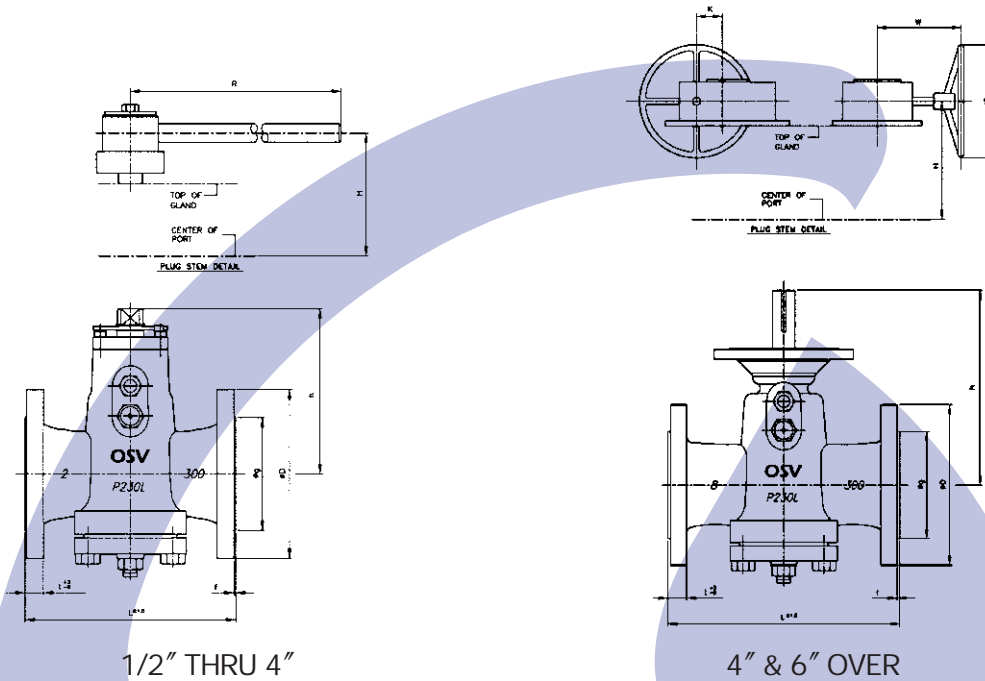

DIMENSIONS

UNIT : MM

IN	MM	L	END FLANGES				BOLT HOLE			h	H	R	K	W	OPERATOR	REMARK
			D	g	t	f	PCD	N	d							
1/2	15	140	95	35	14.3	1.6	66.5	4	16	68	87	180	-	-	WITH	
3/4	20	152	117	43	15.9	1.6	82.5	4	19	68	87	180	-	-	WRENCH	
1	25	165	124	51	17.5	1.6	89.0	4	19	98	125	222	-	-		
1.1/2	40	190	156	73	20.7	1.6	114.5	4	22	148	168	320	-	-		
2	50	216	165	92	22.3	1.6	127.0	8	19	170	182	460	-	-		
2.1/2	65	241	190	105	25.4	1.6	149.0	8	22	205	225	600	-	-		
3	80	283	210	127	28.6	1.6	168.0	8	22	205	225	600	-	-		
4	100	305	254	157	31.8	1.6	200.0	8	22	232	248	750	-	-		
4	100	305	254	157	31.8	1.6	200.0	8	22	232	248	250	53	177	WITH	
6	150	403	318	216	36.6	1.6	270.0	12	22	325	381	300	62.5	228	WORM	
8	200	419	381	270	41.3	1.6	330.0	12	22	382	465	300	62.5	228	GEAR	
10	250	457	444	324	47.7	1.6	387.5	16	29	423	580	500	91.5	297		
12	300	502	521	381	50.8	1.6	451.0	16	32	483	645	560	113	330		
14	350	762	584	413	54.0	1.6	514.5	20	32	525	762	630	153	370		
16	400	838	648	470	57.2	1.6	571.5	20	35	735	814	560	113	360		
18	450	914	711	533	60.4	1.6	628.5	24	35	895	925	630	153	420		
20	500	991	775	584	63.5	1.6	686.0	24	35	945	1025	800	235	552		
24	600	1143	914	692	69.9	1.6	812.8	24	41	1020	1254	900	281	602		

LUBRICATED TYPE PLUG VALVES

P260L Flanged ANSI class 600

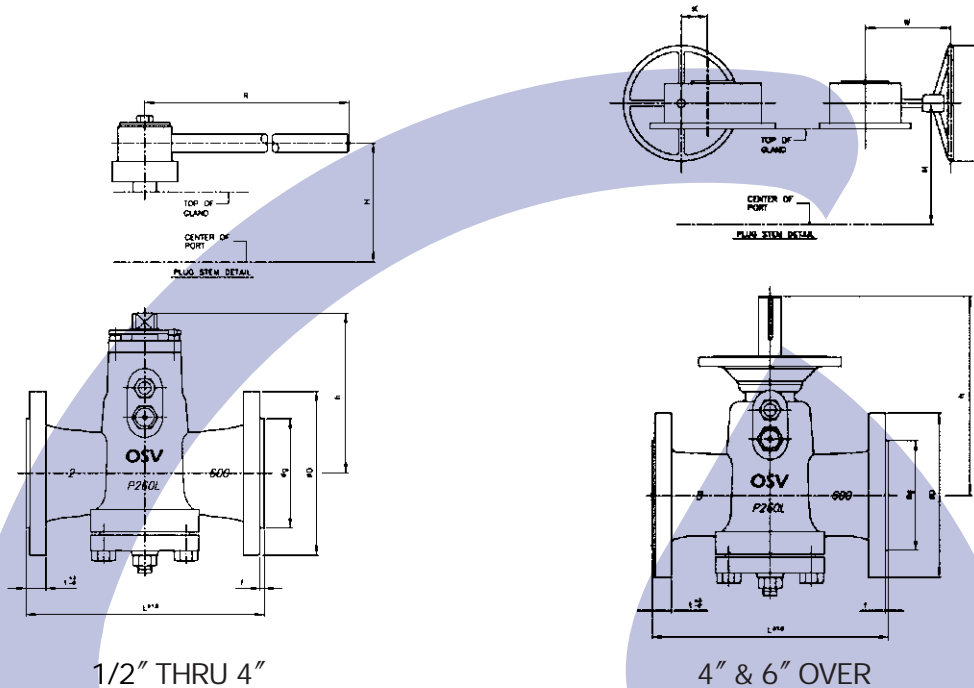

DIMENSIONS

UNIT : MM

IN	MM	L	END FLANGES							h	H	R	K	W	OPERATOR	REMARK
			D	g	t	f	BOLT HOLE									
							PCD	N	d							
1/2	15	165	95	35	20.7	6.4	66.5	4	16	68	87	180	-	-	WITH	
3/4	20	190	117	43	22.3	6.4	82.5	4	19	68	87	180	-	-	WRENCH	
1	25	216	124	51	23.9	6.4	89.0	4	19	98	125	222	-	-		
1.1/2	40	241	156	73	28.7	6.4	114.5	4	22	148	168	320	-	-		
2	50	292	165	92	31.8	6.4	127.0	8	19	170	182	460	-	-		
2.1/2	65	330	190	105	35.0	6.4	149.0	8	22	205	225	600	-	-		
3	80	356	210	127	38.1	6.4	168.0	8	22	205	225	600	-	-		
4	100	432	273	157	44.5	6.4	216.0	8	25	232	248	750	-	-		
4	100	432	273	157	44.5	6.4	216.0	8	25	232	248	250	53	177	WITH	
6	150	559	356	216	54.1	6.4	292.0	12	29	325	381	300	62.5	228	WORM	
8	200	660	419	270	62.0	6.4	349.0	12	32	382	465	300	62.5	228	GEAR	
10	250	787	508	324	69.9	6.4	432.0	16	35	423	580	500	91.5	297		
12	300	838	559	381	73.1	6.4	489.0	20	35	483	645	560	113	330		

NOTES

1. Pressure 900# and above size 12 inch of 600# and above 900#, 1500#,2500# should be made case by case.
2. JIS standard table drawing will be released by OSV separately, when client required.

METAL TYPE PRESSURE BALANCE PLUG VALVES

Lubricated Type

APPLICATION : CHEMICAL, OIL, GAS AND HYDROCARBON PROCESS IN INDUSTRIES

MAXIMUM BREAK TORQUE

- OSV LUBRICATED PLUG VALVES HAVE THE LOWEST POSSIBILITY OF TURNING TORQUE COMPARED WITH TIGHT SHUT-OFF CONDITIONS.
- THE TABLE GIVEN BELOW IS ACTUAL TEST DATA FOR EXPECTED MAXIMUM WORKING CONDITIONS.

UNIT : N.m

	NOMINAL SIZE		CLASS		
	IN	MM	ANSI CLASS150	ANSI CLASS300	ANSI CLASS600
VALVE TORQUE	1	25	33		
	2	60	162	173	210
	3	80	173	249	400
	4	100	303	378	735
	5	150	197	649	1,167
	6	200	1,027	984	2,269
	10	250	1,470	2,475	3,620
	12	300	2,053	2,637	5,823
	14	350	2,053	3,729	5,620
	16	400	2,702	4,648	7,350
	18	460	3,469	6,784	10,593
	20	500	4,626	5,859	17,294
	24	600	5,836	13,295	31,344

NOTES

1. Above table data add 30% safety factor to actual torque data.
2. When sizing an actuator, consult with OSV.



DOUBLE BLOCK & BLEED PLUG VALVES

STRUCTURE OF DOUBLE BLOCK & BLEED PLUG VALVE Non-Lubricated

This system is designed to relieve excess pressure rise in the body cavity of a closed valve due to ambient temperature causing expansion of the liquid in the valve. The relief valve is set to open at 25 PSI on all valves, regardless of their working pressure. With the Double Seal valve closed, the relief valve will open at 25 PSI above upstream pressure. This system functions only when the Double Seal valve is closed and the isolation valve is open.

◆ PLUG VALVE' s characteristic and merits

1. Completely no leakage.

- ① PLUG & Tapered pipe of the Teflon Sleeve uses the contact method giving absolutely no leakage problems compared to other Process Valves.
- ② Stem Seal structure has secured the security design and gives absolutely no leakage characteristic of magnet powered type.
- ③ Weather Proof Type characteristic has been added. The steam seal parts of products of other enterprises leaks and after long usage corrosion takes place in the sealing but our product has used the sealing structure in the stem part and the covering part which gives absolutely no leakage for longtime use eventually increasing the life span of the product. (Top Seal structure)

2. No dead space in the valve.

The passage ways of the valve have no extra space like other Process valve allowing full control and open/close function, semi - permanent life span.

3. No need of maintenance and repair

Having no extra space there is no worry that the moving materials are clogged up inside the pipe.

- ① The Seal pressure made by the abrasion of the Teflon sleeve is re - controlled by the Cover of ADJ. Bolt for semi - permanent sealing.
- ② Inside the Body of the port is a Metal lip with Self-cleaning function which can control all sticky and solid materials.
- ③ Top entry type allowing maintenance in on-line status possible. Valve which doesn't need much maintenance.

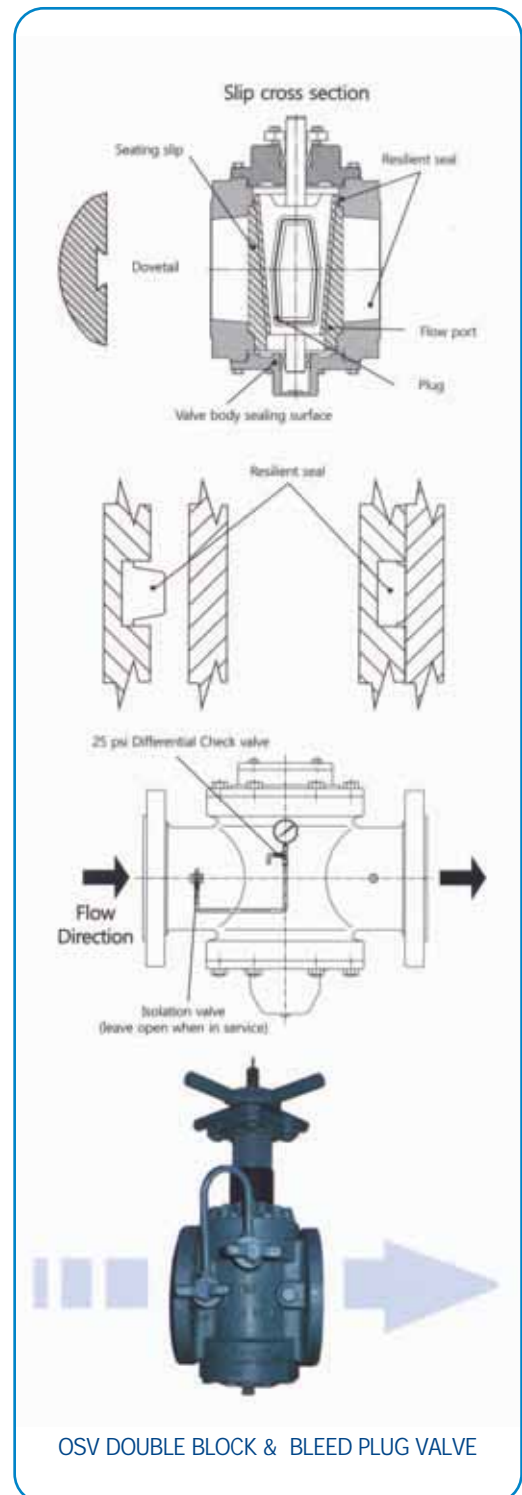

DOUBLE BLOCK & BLEED PLUG VALVE

HOW THIS VALVE WORKS

Non-Lubricated



1) CLOSING

The smaller sizes of Double Seal Valves are handwheel operated and large valves have enclosed weatherproof gearing, but operate in the same manner, requiring proportionately more turns. Turning the operator rotates the plug 90 degrees, aligning the seating slips.



2) COMPRESSING

Turned further, the plug lowers, forcing the seals against the body and compressing them to fit into grooves. With the slip solidly against the body, a secondary metal-to-metal seat forms on both sides of each seal providing double protection. During compressing, the wedging action of the plug forces the seating slips against the valve body.



3) OPENING

During opening, the dovetails pull the slips away from the body. The plug is guided by upper trunnion and then the plug is rotated 90 degrees, aligning the seating slips. In the open position, the seals are completely out of the flow.

CHARACTERISTIC OF DOUBLE BLOCK & BLEED PLUG VALVE Non-Lubricated

◆ Completely no leakage.

A valve selection is very important in petroleum industry. A wrong valve selection causes the decrease of income, the pollution of product and the increase of product line maintenance cost. In multi-product systems, the valves should stand cycle variation of frequent and cut off completely in up-stream sealing and down sealing. The double block and bleeding valve is developed for satisfying a demand fact of metering station, tank farm marine loading docks, blending plant.

◆ Completely no abrasion.

DBB valves can do complete isolation without leakage in a design pressure, and the valve is designed so that a seal doesn't make contact with body of the valve the body during valve opening or closing of the valve. At the last moment of the closing operation, when the seal makes contact with the body, the existing force only consists of a pressure force. A shearing force doesn't be suspended. In all opening, handle operations, the seal is in separated form body, and maintain this state during plug rotation. This takes the abrasion of the seal away and extends the life span.

◆ Double block & bleed

In DBB there are up-stream seals, down-stream seals, and bleed points for each other. So one valve can substitute for two valves and one spool piece, drain. The spool drain sends leakage fluid of valve to tank. The bleed system in this valve is installed to ensure zero leakage.

◆ Complete interception

When the valve is closed, a seat place is in serfed in around plug and body port. An elastic quality of seal is compressed inside groove completely. It is a simple design without using a spring, line pressure, seal differential or brute force for fixing a seal. A sealing of DBB is perfect and can substitute for line blind.

◆ Quick and easy operation

DBB looks like a gate valve, and the operation of DBB is like a ball valve, but it is called a plug valve. Like this, DBB uses only the merit of each valve for complete sealing. The operation mechanism of DBB is an easy operation by minimum rotation.

◆ It is possible to repair on-line?

It is possible to inspect and substitute a seal in on-line DBB
This valve is designed for an easy use substitution and decrease at minimum repair cost.

◆ Operation without a shock

The operation mechanism of DBB is a self locking method, so the force of the fluid from the line doesn't rotate a plug. There aren't plug slaw, line shock and the risk of worker injury. In large size valves it isn't no necessity for attaching gear for catching the shock of line force. Because of this properties, it is changed that petroleum industry business of whole the world like DBB for good efficiency, long life, easy maintenance and low maintenance cost during usage.



DBB valve for complete sealing and the axis makes metal rotation pushing up the valve plug opening the entrance to 90 degrees. The process works in a counter process especially designed for the operation.



PLUG
SLIP BACK FACE
SLIP FRONT FACE
VITON O-RING



BODY

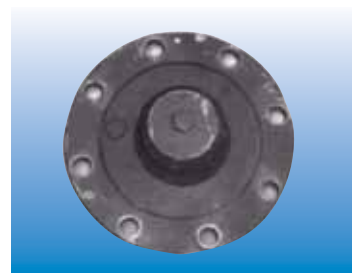

BOTTOM COVER

DBB PLUG VALVE FOR BLEED SYSTEM

Non-Lubricated

Hand bleed valve

It is the most simple method among bleed systems that is worked by hand. When the plug is closed, we open the bleed valve for seeing that sealing is maintained tightly. Before opening the plug, we close bleed valve. <caution 1> A bleed exit faces down vertically and a fluid falls on a fixed hollow and storage, so you prevent privately if the fluid is dangerous or scatters out of sight. You must pay attention to goose neck type the prevents the leakage of body fluid.

Thermal relief to upstream **

When the plug is closed, a thermal relief valve releases the fluid to upstream automatically, if the fluid in closing state does a thermal expansion. A relief valve is adapted for operating at 25psi pressure.

Thermal relief to atmosphere **

It is like a thermal relief to upstream, but it is mediated a fluid emits when the pressure is over 50 psi and the place of emission is waiting not upstream.

Hand bleed valve that has thermal relief **

A hand bleed valve shows a complete sealing and a thermal relief valve makes it possible that any thermal expansion is emitted to upstream safely and automatically. The relief valve is adapted for operating at 25 psi pressure. A relief valve is adapted for opening at 25 psi pressure in all valve. A relief valve in plug-closed is opened when the pressure of upstream is over 25 psi. This system operates only when the plug is closed and the isolation valve is opened. The thermal relief system is designed for decreasing the excess pressure of the body hole in the closed valve. This excess pressure is made when the fluid in the valve expands by high surround temperature. <caution 2> All automatic DBB need a pressure decrease system in the body. If not, the opening is difficult or a fluid sticks in the closed state.

Automatic body bleed valve The cheek valve that is operated by a plunger opens a bleed valve by a coupling cam during the plug valve closing. At this moment the plug of valve can be operated by hand or electric actuator. This system provides a complete automatic system by removing the factor that a human needs to intervene in checking the seal. An isolation valve that is a selection can be fixed in open state to prevent the mistake of checking sealing by human and prove the perfections of DBB valve.

Hand bleed valve that has a gauge-only if the fluid is liquid.

A hand bleed valve connected to a gage is used if you don't want an emission to atmosphere. A gauge always indicates the pressure of body hole and is used for measuring the tightness of sealing in many valve size. You may consult OSV about the pressure change that can occur in the closed state of DBB valve. specific size valve. After time passed, the pressure of body may be changed by heat, so a leakage indication can be wrong by this.

Thermal relief valve that has a gauge-only if the fluid is liquid.

The thermal relief valve for decreasing the pressure of the body that can occur by heat change is used by connecting a gauge for indicating the tightness of the seal. There isn't an emission to the atmosphere. So it is no necessity water receiver system the emission pressure is adapted to 25 psi. <caution 3> When the plug is closed, the cam opens the automatic bleed and the fluid can exit. When the valve is closed completely, the ejecting fluid must stop if the out fluid is dangerous, it is necessary a proper water receiver system.

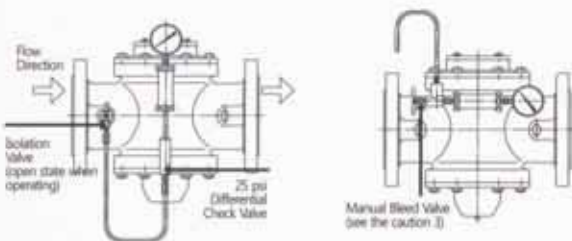
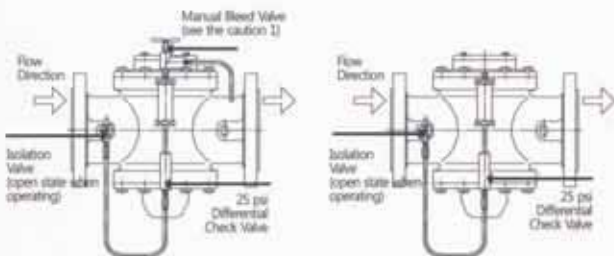
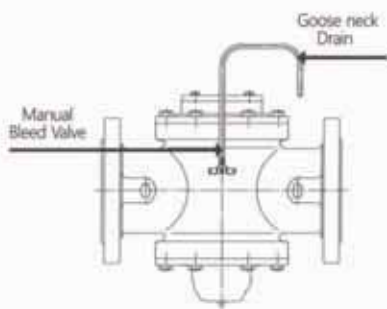

THE DEFINITE CHOICE OF THE OPERATION TOOL. OPERATOR OF DOUBLE BLOCK & BLEED PLUG VALVE Non-Lubricated

◆ Feature

Various operation tools can be supplied in attaching valve as the demand of customer. At order, please indicate a operation tool that is a demand for the operating condition of the valve, and contact with an OSV sales engineer for the definite choice of the operation tool.

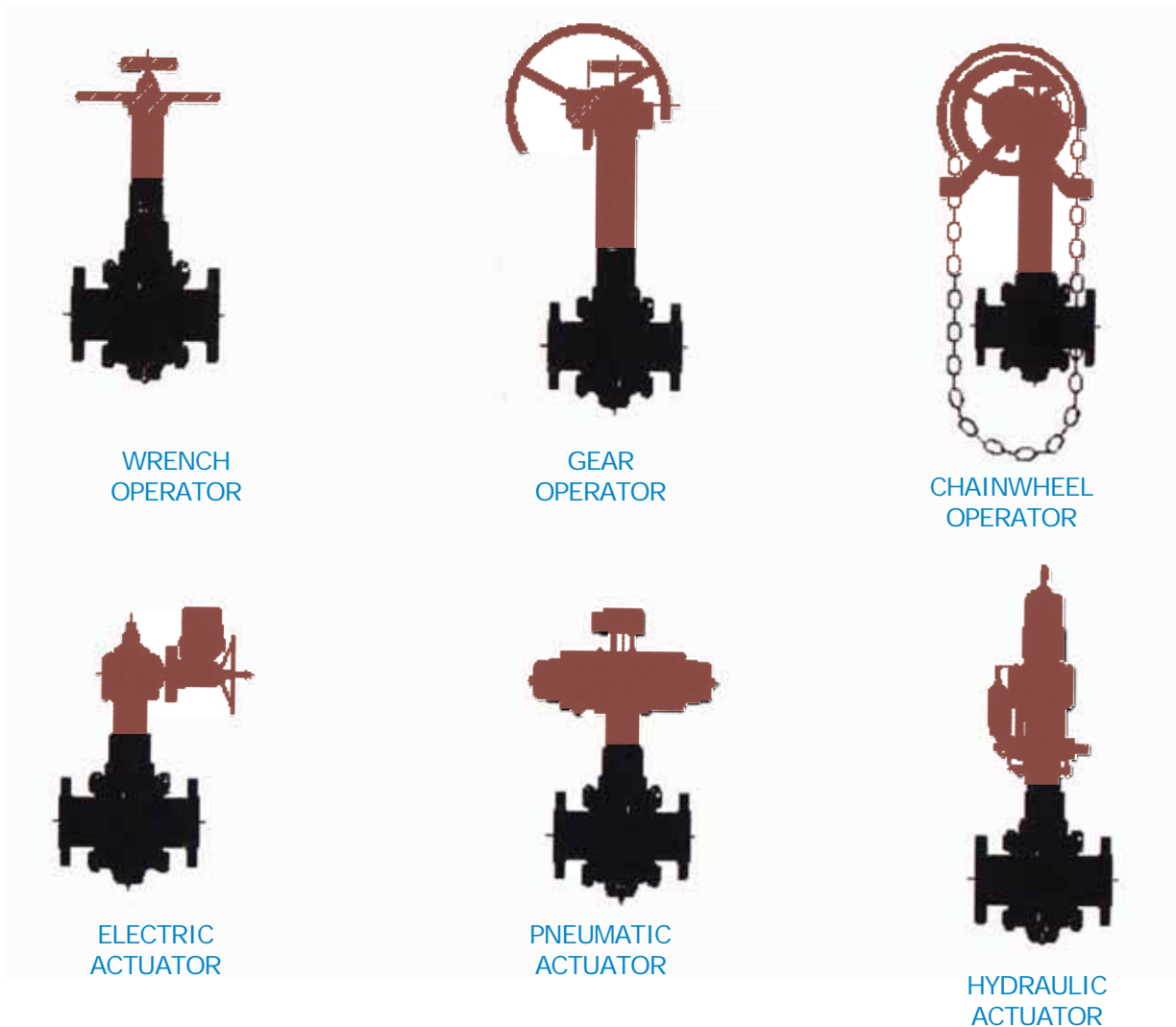

Certificate of Registration

